

Mini Hi-Fi Component System

Operating Instructions

Owner's Record

The model and serial numbers are located on the rear panel. Record the serial number in the space provided below. Refer to them whenever you call upon your Sony dealer regarding this product.

Model No. _____ Serial No. _____



*MHC-F50
MHC-F100
MHC-FR1*

WARNING

To prevent fire or shock hazard, do not expose the unit to rain or moisture.

To avoid electrical shock, do not open the cabinet. Refer servicing to qualified personnel only.

Do not install the appliance in a confined space, such as a bookcase or built-in cabinet.

Laser component in this product is capable of emitting radiation exceeding the limit for Class 1.

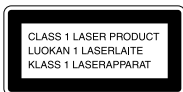

This appliance is classified as a CLASS 1 LASER product. The CLASS 1 LASER PRODUCT MARKING is located on the rear exterior.

This caution label is located inside the unit.



NOTICE FOR THE CUSTOMERS IN THE U.S.A.

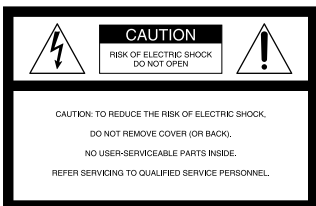

This symbol is intended to alert the user to the presence of uninsulated “dangerous voltage” within the product’s enclosure that may be of sufficient magnitude to constitute a risk of electric shock to persons.



This symbol is intended to alert the user to the presence of important operating and maintenance (servicing) instructions in the literature accompanying the appliance.

CAUTION

The use of optical instruments with this product will increase eye hazard.

INFORMATION

This equipment has been tested and found to comply with the limits for a Class B digital device, pursuant to Part 15 of the FCC Rules. These limits are designed to provide reasonable protection against harmful interference in a residential installation. This equipment generates, uses, and can radiate radio frequency energy and, if not installed and used in accordance with the instructions, may cause harmful interference to radio communications. However, there is no guarantee that interference will not occur in a particular installation. If this equipment does cause harmful interference to radio or television reception, which can be determined by turning the equipment off and on, the user is encouraged to try to correct the interference by one or more of the following measures:

- Reorient or relocate the receiving antenna.
- Increase the separation between the equipment and receiver.
- Connect the equipment into an outlet on a circuit different from that to which the receiver is connected.
- Consult the dealer or an experienced radio/TV technician for help.

CAUTION

You are cautioned that any changes or modifications not expressly approved in this manual could void your authority to operate this equipment.

Note on CATV system installer:

This reminder is provided to call CATV system installer’s attention to Article 820–40 of the NEC that provides guidelines for proper grounding and, in particular, specifies that the cable ground shall be connected to the grounding system of the building, as close to the point of cable entry as practical.

NOTICE FOR THE CUSTOMERS IN CANADA

CAUTION:

TO PREVENT ELECTRIC SHOCK, DO NOT USE THIS POLARIZED AC PLUG WITH AN EXTENSION CORD, RECEPTACLE OR OTHER OUTLET UNLESS THE BLADES CAN BE FULLY INSERTED TO PREVENT BLADE EXPOSURE.

This stereo system is equipped with the Dolby* B-type noise reduction system.

* Dolby noise reduction manufactured under licence from Dolby Laboratories Licensing Corporation. “DOLBY” and the double-D symbol  are trademarks of the Dolby Laboratories Licensing Corporation.

Table of Contents

Getting Started

Step 1 : Hooking up the system	4
Step 2 : Setting the time	6
Step 3 : Presetting radio stations	7
Inserting CDs	8
Connecting optional AV components	10

Basic Operations

Playing a CD	13
Recording a CD	15
Listening to the radio	16
Recording from the radio	17
Playing a tape	18
Recording from a tape	20

The CD Player

Using the CD display	21
Playing the CD tracks repeatedly	22
Playing the CD tracks in random order	22
Programming the CD tracks	23
Playing your favorite CD independently	25
Labelling a CD*	26
Locating a specific CD*	28
Playing highlights of the CD*	29

The Tape Deck

Recording on a tape manually	30
Recording a CD by specifying track order	31

DJ Effects

Looping part of a CD	33
Flashing part of a CD	33

Sound Adjustment

Adjusting the sound	34
Selecting the audio emphasis	35
Adjusting the audio emphasis	36
Making a personal audio emphasis file	38

Other Features

Singing along : Karaoke**	39
Falling asleep to music	40
Waking up to music	41
Timer-recording radio programs	42

Additional Information

Precautions	44
Troubleshooting	45
Specifications	48
Index	50

* For MHC-F100/MHC-FR1 only

** For Singaporian model only

Step 1: Hooking up the system

Do the following procedure **1** to **5** to hook up your system using the supplied cords and accessories. To complete the setup, do steps 2 and 3 also.

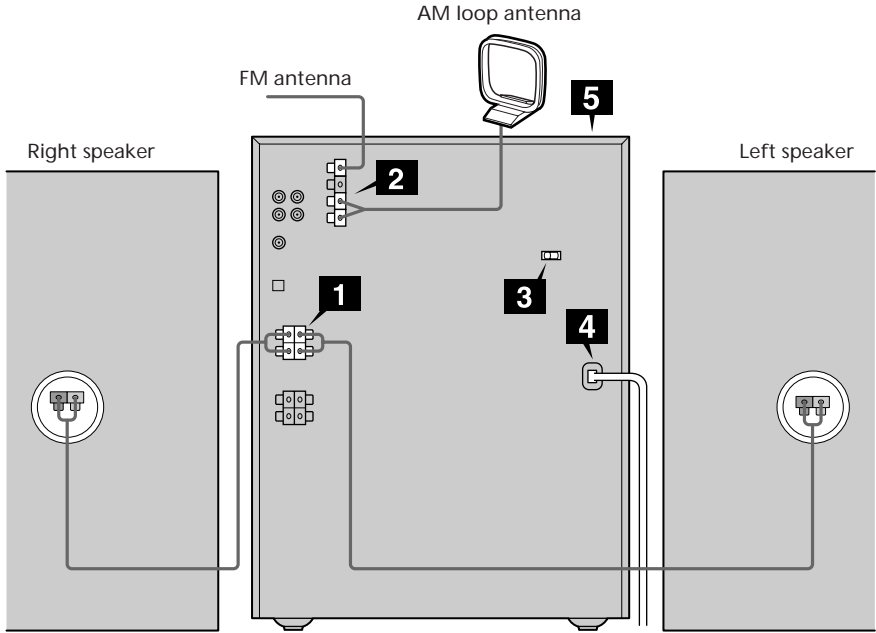

MHC-FR1 is used for illustration purpose.

1 Connect the speakers.

Connect the speaker cords to the SPEAKER jacks of the same color. Keep the speaker cords away from the antennas to prevent noise.

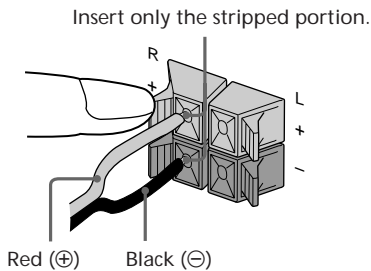

2 Connect the FM/AM antennas.

Set up the AM loop antenna, then connect it.

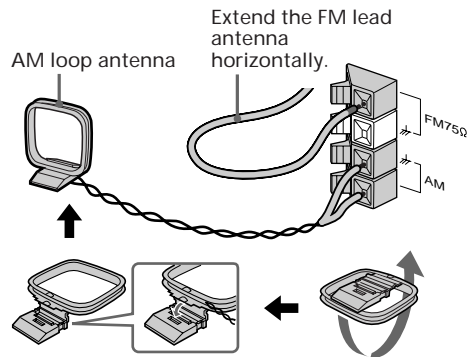

-
- 3** Set **VOLTAGE SELECTOR** to position of your local power line voltage (except for North American, and Australian models).

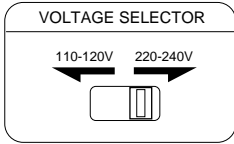

-
- 4** Connect the power cord to a wall outlet. Demo mode appears in the display. If the plug on this unit does not fit your wall outlet, detach the supplied adapter from the plug (only for Singapore).

-
- 5** Deactivate the demo mode by pressing **DISPLAY/DEMO** when the system power is turned off. The demo mode is also deactivated when you set the time.
-

Inserting two size AA (R6) batteries into the remote

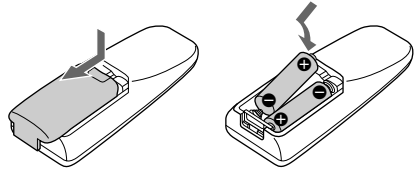

Tip

With normal use, the batteries should last for about six months. When the remote no longer operates the system, replace both batteries with new ones.

Note

If you do not use the remote for a long period of time, remove the batteries to avoid possible damage from battery leakage.

Note on placement

Be sure to place this system on a horizontal place. If the system is slanted, it may cause malfunction or damage the system.

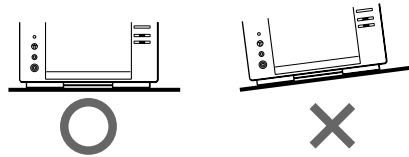

Step 2: Setting the time

You must set the time before using the timer functions.

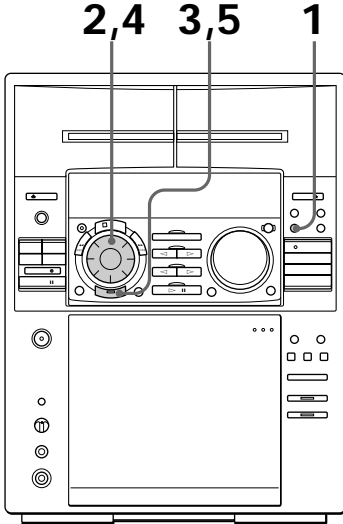

4 Turn the jog dial to set the minute.

5 Press ENTER.
The clock starts working.

Tips

- If you've made a mistake, start over from step 1.
- Setting the time deactivates the demo mode .
If you want to display the demo mode, press DISPLAY/DEMO when the power is off.

1 Press \ominus /CLOCK SET.
The hour indication flashes.

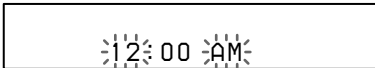

2 Turn the jog dial to set the hour.
The clock is on a 12-hour system.

3 Press ENTER.
The minute indication flashes.

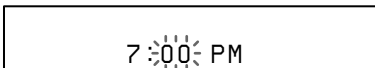

Inserting CDs

You can insert up to 51 discs into this player. We recommend you use the PLUS ONE slot for CDs you will be inserting and removing frequently (see page 25).

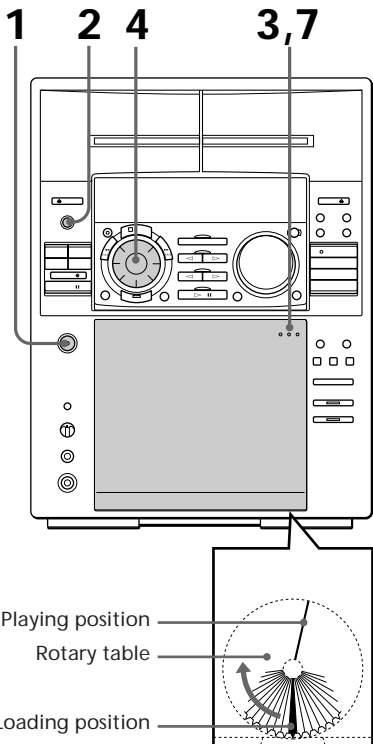

- 1 Press **POWER** to turn on the player.
- 2 Press **FUNCTION** repeatedly until "CD" appears.

- 3 Open the front cover by pushing the right edge of the cover.

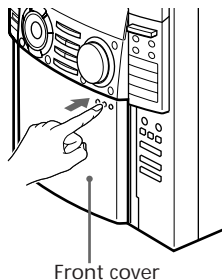

- 4 Turn the jog dial until you find the disc slot where you want to insert a disc, while checking the disc number (written beside every slot and also indicated in the display).

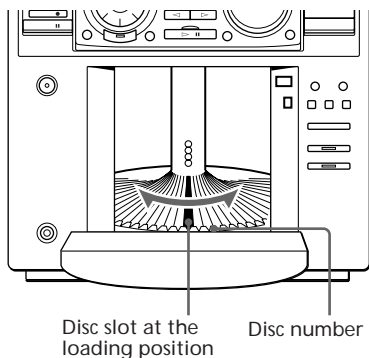

The disc number* or disc title (for MHC-F100/MHC-FR1 only, see page 26 for details) at the loading position appears in the display. As you turn the jog dial, the disc number or the disc title changes.

* If you have already inserted discs, the disc number at the playing position appears. When you turn the jog dial, the displayed disc number changes to the one at the loading position.

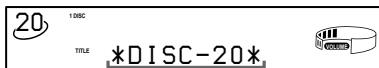

Disc number or the disc title

5 Insert a disc with the label side facing right.

Notes

- Make sure you have inserted the disc into each slot at a right angle to the rotary table. If the disc is not put in straight, it may damage the player or the disc.
- Make sure the rotary table comes to a complete stop before inserting or removing discs.

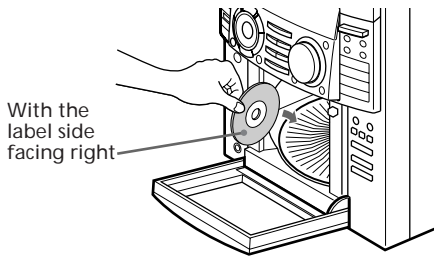

6 Repeat steps 4 and 5 to insert more discs.

7 Close the front cover by pushing the right edge of the cover until it clicks.

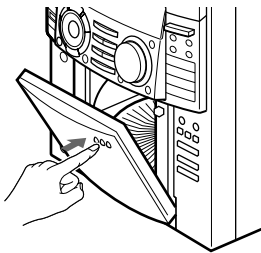

The rotary table turns and the disc slot at the loading position is set to the playing position.

Always close the front cover except when you insert or remove discs.

Removing CDs

After following Steps 1 to 3 of “Inserting CDs” on page 8, remove the discs. Then close the front cover.

Notes

- Do not insert an empty 8 cm (3-inch) CD adaptor. It may damage the player.
- Do not attach anything such as seals or sleeves to CDs. It may damage the player or the disc.
- If you drop a disc into the player and the CD won't go into the slot correctly, consult your nearest Sony dealer.
- When transporting the player, remove all discs from the player.
- If you want to remove the disc played, press ENTER after opening the front cover. The disc comes to the loading position. Remove the disc after the rotary table comes to a complete stop.

Tips

- To play the disc you want independently, see “Playing your favorite disc independently” on page 25.
- You can display the original disc titles instead of the disc numbers to locate it easily when you start playing.

When you select a CD-TEXT disc, the disc title is displayed instead of the disc number (for MHC-F100/MHC-FR1 only, see page 26 for details).

Connecting optional AV components

To enhance your system, you can connect optional components. Refer to the instructions of each component.

MHC-FR1 is used for illustration purpose.

Connecting a VCR

Make sure to match the color of the plugs and the connectors. To listen to the sound of the connected VCR, press FUNCTION repeatedly until "VIDEO" appears.

To the audio output of the VCR

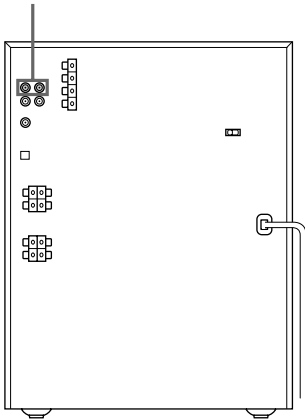

Note

If the sound is distorted when selecting "VIDEO", switch to "MD" (see "Before connecting an MD deck" on this page).

Connecting audio components

Select one of the following two connections, depending on the equipment to be connected and method of connecting.

Before connecting an MD deck

Press FUNCTION repeatedly until "MD" appears on the display.

When "VIDEO" appears by pressing FUNCTION, change the indication to "MD" following the procedure.

- 1 Press FUNCTION repeatedly until "VIDEO" appears.
- 2 Turn the power off, then press POWER while holding down GROOVE. "VIDEO" on the display will switch to "MD".

To return to "VIDEO", repeat the same step.

Connecting an MD deck for digital recording (For MHC-F100/MHC-FR1 only)

You can record from CD into the MD deck digitally by connecting an optical cable.

To the DIGITAL IN jack of the MD deck

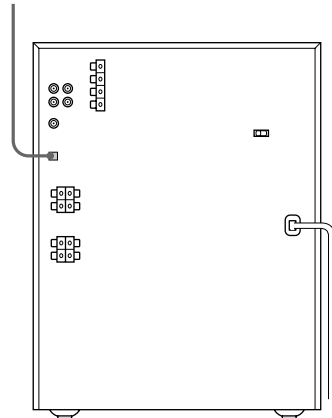

Connecting an MD deck for analog recording

Make sure to match the color of the plugs and the connectors. To listen to the sound of the connected MD deck, press FUNCTION repeatedly until "MD" appears.

To the audio output of the MD deck To the audio input of the MD deck

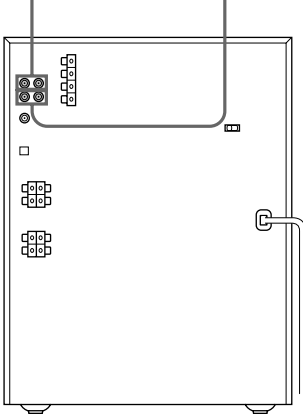

Connecting surround speakers (For MHC-F100/MHC-FR1 only)

You can connect an optional surround speakers.

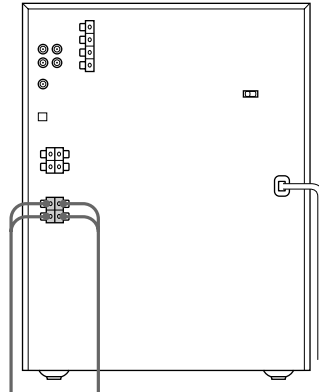

To surround speaker (R) To surround speaker (L)

Note

You need to connect both left and right surround speakers. Otherwise, the sound will not be heard.

Tip

If you connect a turntable with MM cartridge, connect it to VIDEO/MD IN using the optional MM cartridge equalizer and an audio connecting cord. To listen to the sound, press FUNCTION repeatedly until "VIDEO" appears.

continued

Connecting a super woofer speaker (For MHC-F100/MHC-FR1 only)

You can connect an optional super woofer speaker.

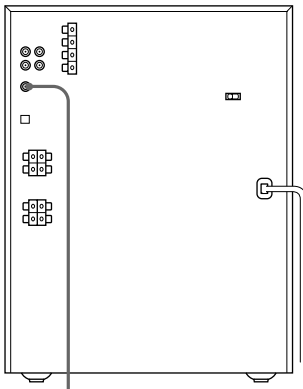

To super woofer

Connecting optional AV components (continued)

Connecting outdoor antennas

Connect the outdoor antenna to improve the reception.

FM antenna

Connect the optional FM outdoor antenna. You can also use the TV antenna instead.

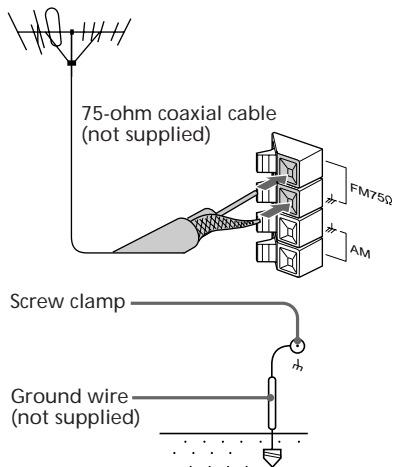

AM antenna

Connect a 6- to 15- meter (20- to 50- feet) insulated wire to the AM antenna terminal. Leave the supplied AM loop antenna connected.

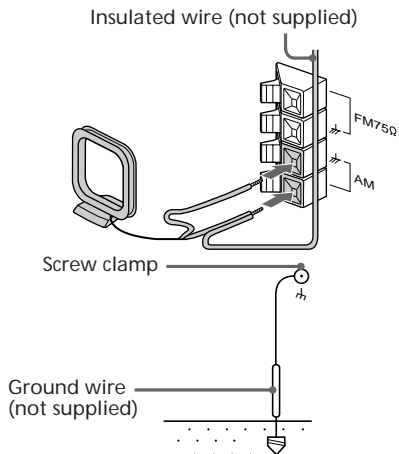

Important

If you connect an outdoor antenna, ground from *h* terminal with the screw clamp. To prevent a gas explosion, do not connect the ground wire to a gas pipe.

Playing a CD

— Normal play

You can play up to 51 CDs in a row.

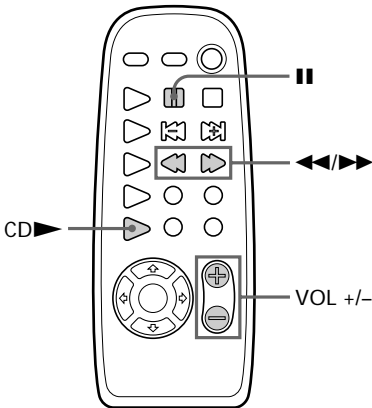
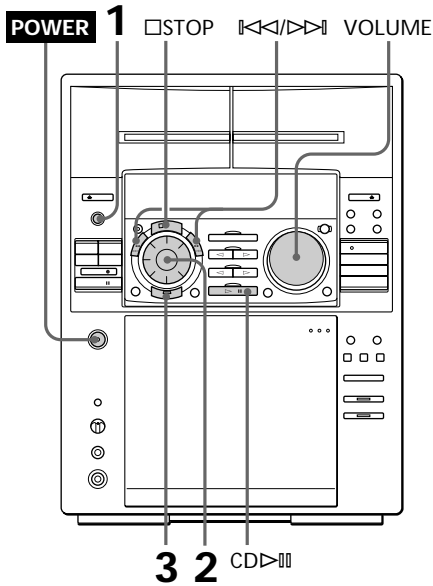

- 1 Press **FUNCTION** repeatedly until "CD" appears.
- 2 Turn the jog dial until the desired disc number or the disc title* appears.

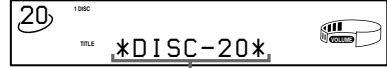

Disc number or the disc title

- 3 Press **ENTER** or CD >|| (or CD ▶ on the remote)
- The selected disc is set to the playing position, and starts playing.

* For MHC-F100/MHC-FR1 only, see page 26 for details.

continued

Playing a CD (continued)

To	You need to
Stop play	Press \square STOP.
Pause	Press CD $\triangleright \square$ (on the remote).
Resume playing after pause	Press CD $\triangleright \square$ (on the remote).
Select a CD	Turn the jog dial clockwise (or press \blacktriangleright on the remote) or counterclockwise (or press \blacktriangleleft on the remote) and release it when you reach the desired CD.
Select a track	During play or pause, press $\triangleright \triangleright$ (to go forward) or $\triangleleft \triangleleft$ (to go back) until you reach the desired track.
Advance or return 10 CDs at a time	Press \blacktriangleup on the remote (to move 10 CDs ahead) or \blacktriangledown (to move 10 CDs back).
Find a point of a track	Press and hold down $\blacktriangleright \blacktriangleright$ (to go forward) or $\blacktriangleleft \blacktriangleleft$ (to go back) on the remote during a play and release it at the desired point.
Play only the CD you have selected	Press CONTINUE repeatedly until "1 DISC" appears.
Play all CDs	Press CONTINUE repeatedly until "ALL DISCS" appears.
Adjust the volume	Turn VOLUME (or press VOL +/- on the remote).
Stop playing and remove the disc	Open the front cover, then press ENTER. The PLUS ONE slot comes out automatically when the front cover is opened while the CD PLUS ONE button is lit up.

To specify the next CD to play

While playing a disc, turn the jog dial until the desired disc number (or disc title) and "NEXT" appears. To skip to the next disc right away, press ENTER.



To cancel the specified disc, press CONTINUE twice.

Tips

- Pressing CD $\triangleright \square$ when the power is off automatically turns the power on and starts CD playback if there is a CD in the tray (One Touch Play).
- You can switch from another source to the CD player and start playing a CD just by pressing CD $\triangleright \square$ (Automatic Source Selection).
- If there is no CD in the player, "NO DISC" appears.

Recording a CD

— CD Synchro Recording

The CD SYNCHRO button lets you record from a CD to a tape easily. You can use TYPE I (normal) or TYPE II (CrO₂) tapes. The recording level is adjusted automatically.

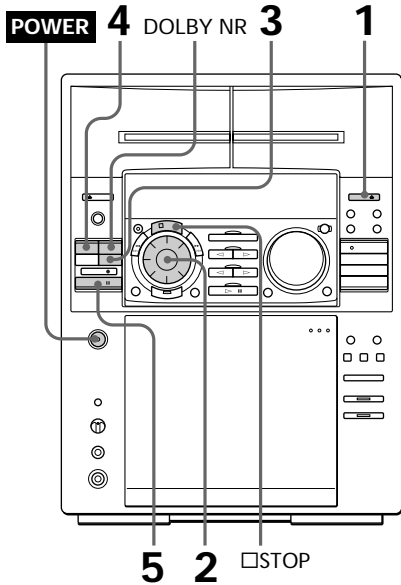

- 1 Press EJECT and insert a blank tape into deck B.

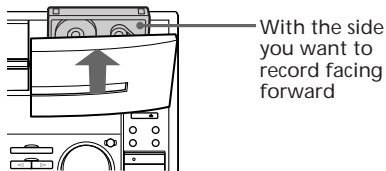

With the side you want to record facing forward

- 2 Turn the jog dial until the desired disc number or the disc title (see page 26) appears.

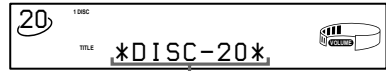

Disc number or the disc title

- 3 Press CD SYNCHRO. Deck B stands by for recording and the CD player stands by for playback. (for front side) lights up.
- 4 Press DIRECTION repeatedly to select to record on one side. Select (or RELAY) to record on both sides.
- 5 Press PAUSE . Recording starts.

To stop recording

Press STOP.

Tips

- If you want to record from the reverse side, press TAPE B so that (for reverse side) lights up.
- When you record on both sides, be sure to start from the front side. If you start from the reverse side, recording stops at the end of the reverse side.
- When you want to reduce the hiss noise in low-level high-frequency signals, press DOLBY NR so that "DOLBY NR B" appears after pressing CD SYNCHRO.

Note

You cannot listen to other sources while recording.

Listening to the radio

— Preset Tuning

Preset radio stations in the tuner's memory first (see "Step 3: Presetting radio stations").

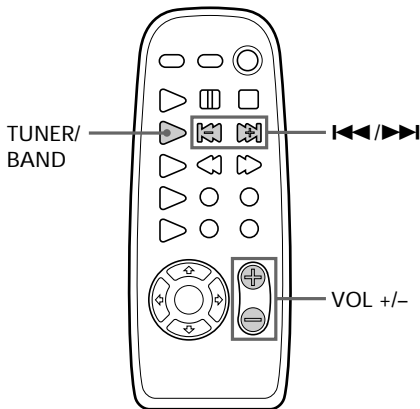
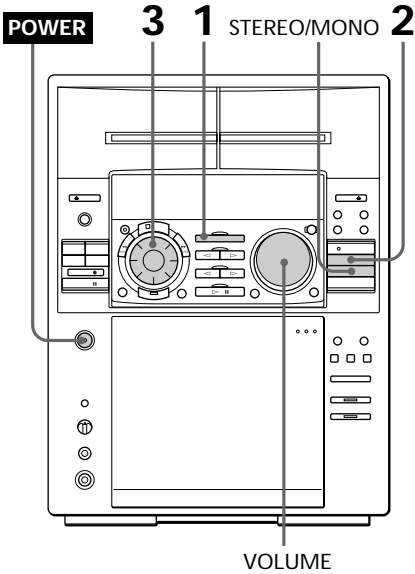

- 1 Press TUNER/BAND repeatedly until the band you want appears. Each time you press the button, the band changes as follows:

Singaporean model:
FM → MW → SW

North and South American and Australian models:
FM ↔ AM

- 2 Press TUNING MODE repeatedly until "PRESET" appears.
MANUAL → AUTO → PRESET

- 3 Turn the jog dial (or press ◀◀ or ▶▶ on the remote) to tune in the desired preset station.

Turn counter-clockwise (or press ◀◀ on the remote) for lower preset numbers.

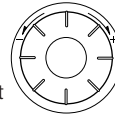

Turn clockwise (or press ▶▶ on the remote) for higher preset numbers.

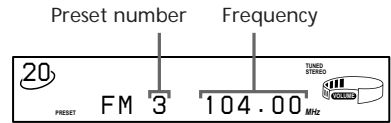

To	Do this
Turn off the radio	Press POWER.
Adjust the volume	Turn VOLUME (or press VOL +/- on the remote).

To listen to non-preset radio stations

Press TUNING MODE repeatedly until "MANUAL" or "AUTO" appears in step 2, then tune in the station by turning the jog dial.

Tips

- Pressing TUNER/BAND when the power is off automatically turns the power on and tunes to the last received station (One Touch Play).
- You can switch from another source to the radio just by pressing TUNER/BAND (Automatic Source Selection).
- When an FM program is noisy, press STEREO/MONO repeatedly until "MONO" appears in the display. There will be no stereo effect, but the reception will improve. Press the button again to restore the stereo effect.
- To improve broadcast reception, reorient the supplied antennas.

Recording from the radio

You can record the radio program on a tape by calling up a preset station. You can use TYPE I (normal) or TYPE II (CrO₂) tapes. The recording level is automatically adjusted.

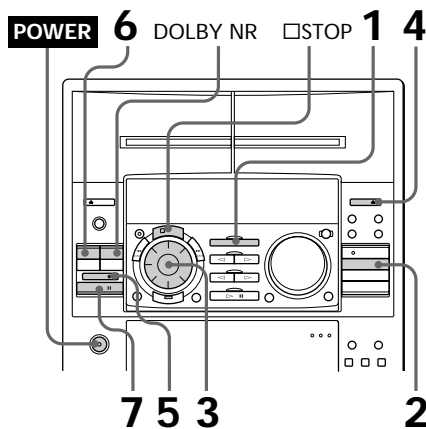

- 1 Press TUNER/BAND repeatedly until the band you want appears.
- 2 Press TUNING MODE repeatedly until "PRESET" appears.
- 3 Turn the jog dial to tune in the desired preset station.

Turn counter-clockwise for lower preset numbers.

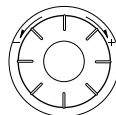

Turn clockwise for higher preset numbers.

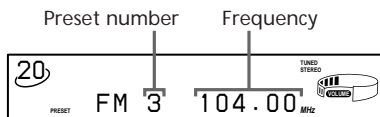

continued

Recording from the radio (continued)

- 4** Press \triangle EJECT and insert a blank tape into deck B.

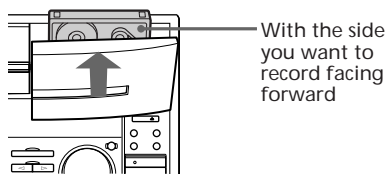

- 5** Press REC \circ .
Deck B stands by for recording.

- 6** Press DIRECTION repeatedly to select \rightleftarrows to record on one side. Select \leftrightarrow (or RELAY) to record on both sides.

- 7** Press PAUSE \square .
Recording starts.

To stop recording

Press \square STOP.

Tips

- If you want to record from the reverse side, press TAPE B \triangleleft so that \triangleleft (for reverse side) lights up.
- When you record on both sides, be sure to start from the front side. If you start from the reverse side, recording stops at the end of the reverse side.
- You can still rewind or fast-forward Deck B by pressing the \triangleleft or \triangleright keys on the main unit, even while using the tuner.
- To record non-preset stations, select "MANUAL" in step 2, then turn the jog dial to tune in the desired station.
- When you want to reduce the hiss noise in low-level high-frequency signals, press DOLBY NR so that "DOLBY NR B" appears before step 7.
- If noise is heard while recording from the radio, move the respective antenna to reduce the noise.

Playing a tape

You can use any type of tape, TYPE I (normal), TYPE II (CrO₂) or TYPE IV (metal), since the deck automatically detects the tape type.

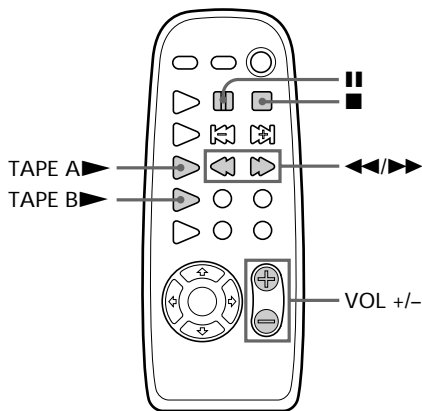
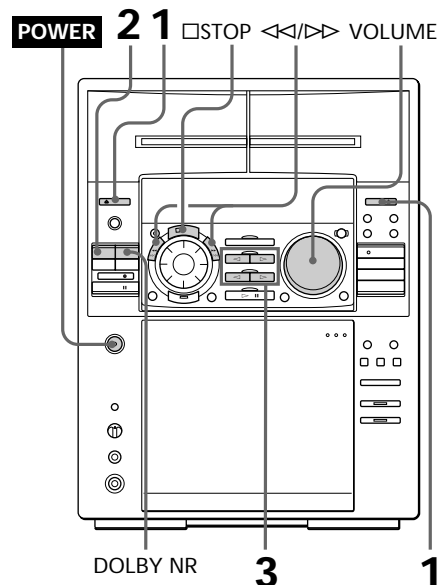

1 Press **EJECT** and insert a recorded tape in deck A or B.

With the side you want to play facing forward



Tips

- Pressing TAPE A $\triangleleft/\triangleright$ or TAPE B $\triangleleft/\triangleright$ when the power is off automatically turns the power on and starts tape playback if there is a tape in the deck (One Touch Play).
- You can switch from another source to the tape deck just by pressing TAPE A $\triangleleft/\triangleright$ or TAPE B $\triangleleft/\triangleright$ (Automatic Source Selection).
- When you play a tape recorded with Dolby NR B, press DOLBY NR so that "DOLBY NR B" appears.

2 Press **DIRECTION** repeatedly to select \rightleftarrows to play one side. Select \leftrightarrow * to play both sides.

To play both decks in succession, select **RELAY** (relay play).**

3 Press TAPE A \triangleright or TAPE B \triangleright . Press \triangleleft (or TAPE A \blacktriangleright or TAPE B \blacktriangleright on the remote again) to play the reverse side. The tape starts playing.

* The deck stops automatically after repeating the sequence five times.

** Relay play always follows the following sequence:
Deck A (front side), Deck A (reverse side), Deck B (front side), Deck B (reverse side).

To	Do this
Stop play	Press \square STOP (or \blacksquare on the remote).
Pause (Deck B only)	Press PAUSE $\square\square$ (or $\blacksquare\blacksquare$ on the remote). Press again to resume play.
Fast-forward	Press $\triangleright\triangleright$ while playing the front side or $\triangleleft\triangleleft$ while playing the reverse side. This fast-forwards the deck shown on the display (TAPE A or TAPE B).
Rewind	Press $\triangleleft\triangleleft$ while playing the front side or $\triangleright\triangleright$ while playing the reverse side. This rewinds the deck shown on the display (TAPE A or TAPE B).
Remove the cassette	Press EJECT .
Adjust the volume	Turn VOLUME (or press VOL +/- on the remote).

Recording from a tape

— High-speed Dubbing

You can use TYPE I (normal) or TYPE II (CrO₂) tapes. The recording level is automatically adjusted.

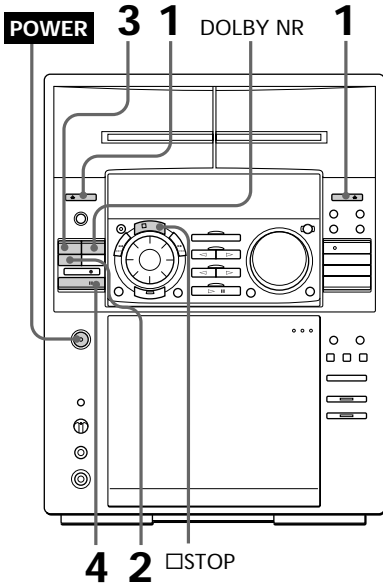

- 1 Press EJECT and insert a recorded tape in deck A and a blank tape in deck B.

With the side you want to play/record facing forward

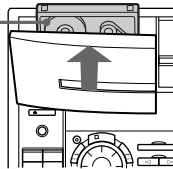

- 2 Press HI-SPEED DUBBING.
Deck B stands by for recording.
- 3 Press DIRECTION repeatedly to select to record on one side. Select (or RELAY) to record on both sides.

- 4 Press PAUSE .
Dubbing starts.

To stop dubbing

Press STOP.

Tips

- When you dub on both sides, start recording from the front side. If you record from the reverse side, recording stops at the end of the reverse side.
- If you set DIRECTION to when the tapes you use have different lengths, the tape in each deck reverses independently. If you select RELAY, the tapes in both decks reverse together.
- When you record a tape recorded with Dolby NR B in deck A, press DOLBY NR so that "DOLBY NR B" disappears. The tape is recorded with Dolby NR B.

Using the CD display

You can check the remaining time of the current track or that of the CD.

- ¹⁾ For labeled CD or CD with CD-TEXT (For MHC-F100/MHC-FR1 only)
- ²⁾ CD with CD text (For MHC-F100/MHC-FR1 only)
- ³⁾ TOC = Table of Contents; displays current disc number, track number, playing time of the track.

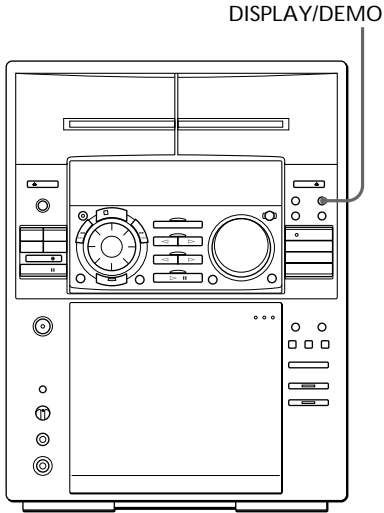

➔ Press DISPLAY/DEMO.

Each time you press the button, the display changes as follows:

During the stop

- ➔ disc number or disc title¹⁾
- ↓
- Artist name²⁾
- ↓
- TOC display³⁾
- ↓
- Clock display (for a few seconds)
- ↓
- Effect (P FILE) name or "EFFECT ON (OFF)"

During the normal play

- ➔ Playing time on the current track
- ↓
- Track title²⁾
- ↓
- Clock display (for a few seconds)
- ↓
- Effect (P FILE) name or "EFFECT ON (OFF)"

Playing the CD tracks repeatedly

-- Repeat Play

This function lets you repeat a single CD or all CDs in normal play, Shuffle Play and Program Play.

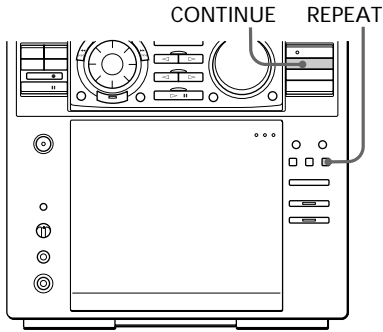

- ➔ Press REPEAT during play until "REPEAT" appears. Repeat play starts. Do the following procedure.

To repeat	Press
All the tracks on the current CD	CONTINUE repeatedly until "1 DISC" appears.
All the tracks on all CDs	CONTINUE repeatedly until "ALL DISCS" appears.
Only one track	REPEAT repeatedly until "REPEAT 1" appears while playing the track you want to repeat.

To cancel Repeat Play

Press REPEAT repeatedly until "REPEAT" or "REPEAT 1" disappears.

Playing the CD tracks in random order

-- Shuffle Play

You can play all the tracks on one CD or all CDs in random order.

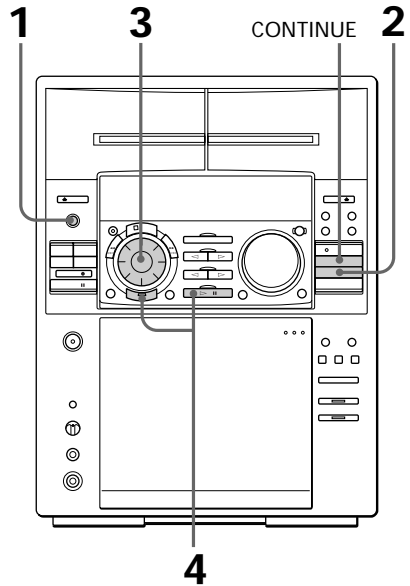

- 1 Press FUNCTION repeatedly until "CD" appears.
- 2 Press SHUFFLE to select ALL DISCS or 1 DISC Shuffle Play mode. Each time you press SHUFFLE, "ALL DISCS" or "1 DISC" appears.

To play	Select
All tracks on all discs in random order	ALL DISCS
All tracks on the specific disc in random order	1 DISC

- 3 When you want to specify the disc for 1 DISC Shuffle Play, turn the jog dial until the desired disc number or disc title (see page 26) appears.

-
- 4** Press ENTER or CD ▷◁. "CD" appears and then all the tracks play in random order.
-

To cancel Shuffle Play

Press CONTINUE.

Tips

- You can start Shuffle Play by pressing SHUFFLE while playing.
- You can specify the next disc to play during 1 DISC Shuffle Play. Turn the jog dial to specify the next disc. After all the tracks on the current disc are played in random order, the next disc starts playing. To skip to the next disc right away, press ENTER while playing the current disc. You cannot specify the next disc to play during ALL DISCS Shuffle Play.

Note

Even if you press □STOP or turn off the power during ALL DISCS Shuffle Play, the player remembers which discs/tracks were played and which were not. Therefore, if you want to start ALL DISCS Shuffle Play again from the beginning, be sure to repeat the procedure from Step 1.

Programming the CD tracks

-- Program Play

You can arrange the order of the tracks and/or discs to create three different programs and programs are stored automatically. A program can contain up to 32 "steps" — one "step" may contain a track or a whole disc.

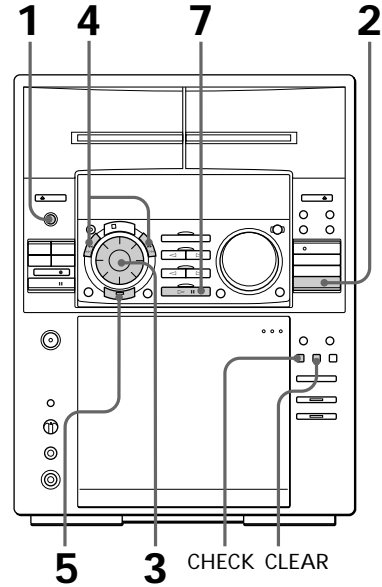

-
- 1** Press FUNCTION repeatedly until "CD" appears.
-
- 2** Press PROGRAM repeatedly until the desired program number (PROGRAM 1, 2 or 3) appears.
-
- 3** Turn the jog dial until the desired disc number appears.

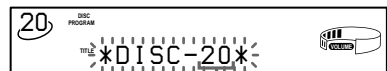

Disc number

continued

Programming the CD tracks (continued)

- 4** To program a whole disc, skip this step. Press \llcorner/\triangleright until the desired track number appears.

When the disc you select has a disc title (For MHC-F100/MHC-FR1 only), it appears and then switches to the following display.

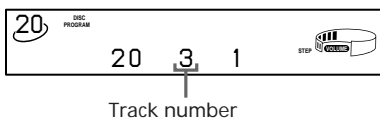

- 5** Press ENTER.

The track is programmed.

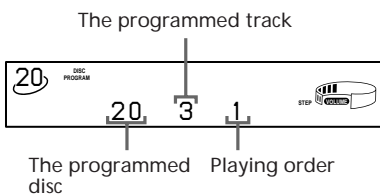

- 6** To program other discs/tracks, do the following:

To program	Repeat Steps
Other discs	3 and 5
Other tracks on the same disc	4 and 5
Other tracks on other discs	3 to 5

- 7** Press CD \triangleright .

All the tracks play in the order you selected.

To	You need to
Check the program	Press CHECK repeatedly. After the last track, "END" appears.
Clear a specific track or disc	Press CHECK until the track or disc you do not want appears, then press CLEAR.
Clear from the last track or disc	Press CLEAR. Each time you press the button, the last track or disc will be cleared.
Add tracks or discs to the end of the program	Follow the programming procedure.
Clear a specific program	1 Press PROGRAM repeatedly until the program number you want to clear appears. 2 Hold down CLEAR until "ALL CLEAR" appears.

Tips

- When you press CD \triangleright , you can play the same program again.
- If you replace discs, the programmed disc and track numbers remain until you erase them. So, the player plays only the existing disc and track numbers. However, the disc and track numbers that are not found in the player or on the disc are deleted from the program, and the rest of the program is played in the programmed order.

To cancel Program Play

Press CONTINUE.

Playing your favorite CD independently

— Plus One Play

When you insert a disc into the PLUS ONE slot, you can play the disc independently from other discs. When using this function, the player is automatically set to 1 DISC Continuous Play mode.

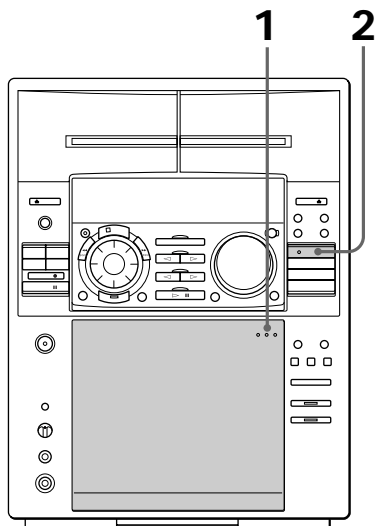

- 1** Open the front cover.
- 2** Press CD PLUS ONE (or PLUS ONE on the remote).
The indicator on the CD PLUS ONE button lights up.

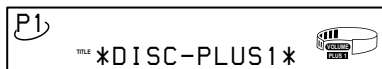

The PLUS ONE slot comes to the loading position.

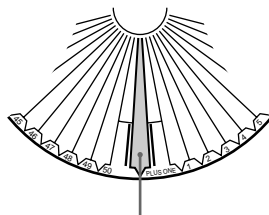

PLUS ONE slot

- 3** Insert a disc into the PLUS ONE slot.
- 4** Close the front cover.
The player starts playing the disc in the PLUS ONE slot.
When the disc you select has a disc title (For MHC-F100/MHC-FR1 only) this is displayed along with "PLUS1".

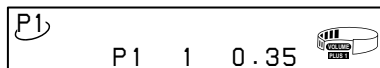

To cancel Plus One Play

Press CD PLUS ONE (or PLUS ONE on the remote). The indicator on the CD PLUS ONE button goes off. The disc number in the display changes to 51 and you can play the disc as the 51st disc.

continued

Playing Your Favorite CD Independently (continued)

Tips

- To play a disc already inserted into the PLUS ONE slot, press CD PLUS ONE while the front cover is closed.
- You can start Shuffle Play during Plus One Play by pressing SHUFFLE before step 4.

Notes

- Plus One Play will be canceled if:
 - you turn the jog dial or press buttons to specify the other disc.
 - you press PROGRAM, MEMO SCAN or MEMO SEARCH.
- The PLUS ONE slot comes to the loading position automatically if you open the front cover during Plus One Play. Do not put your hand inside the compartment nor change the disc before the rotary table comes to a complete stop. If you do, you may injure your hand or damage the disc.

Labeling a CD

(For MHC-F100/MHC-FR1 only)

— Disc Memo

You can label each disc using up to 12 characters. When you select a CD-TEXT disc, the first 12 characters of the disc title are stored as a disc memo. Whenever you load the labelled CD, the label (disc title) appears in the display.

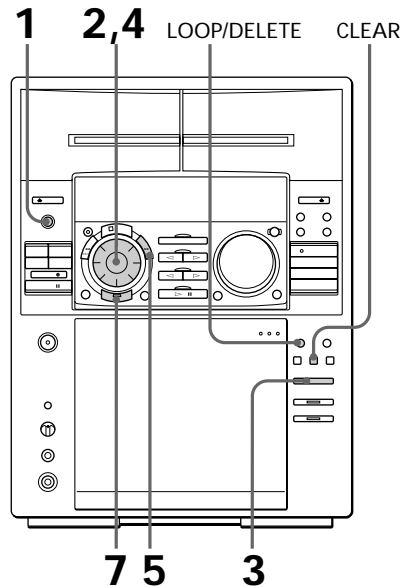

1 Press FUNCTION repeatedly until "CD" appears.

2 Turn the jog dial until the disc number to which you want to label appears.

When you label a disc with the front cover closed, the disc number of the disc at the playing position appears.

When you label a disc with the front cover open, the disc number at the loading position appears.

3 Press MEMO INPUT.

The cursor (◀) starts flashing.

4 Turn the jog dial until the desired character appears.

The cursor disappears and the first space for the disc title flashes.

To select characters on the unit

As you turn the jog dial clockwise, the characters appear in the following order. Turn the jog dial counterclockwise to go back to the previous character.

To select characters on the remote

Press \uparrow or \downarrow until the desired type of character appears, then press \leftarrow or \rightarrow until the desired character appears.

(space) A B C D E F G H I J K L M N O P
Q R S T U V W X Y Z a b c d e f g h i j k l
m n o p q r s t u v w x y z 0 1 2 3 4 5 6 7 8
9 ! " # \$ % & ' () * + , - . / : ; < = > ? @ [\
] ^ _ ` { | } ~



5 Press $\triangleright\triangleleft$ to select the character.

The cursor shifts rightward and waits for the input of the next character.

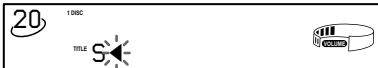

If you have made a mistake

Press LOOP/DELETE. The character 1 space before the cursor disappears and the cursor flashes. Input the correct characters.

6 Repeat Steps 4 and 5 to input more characters.

7 Press ENTER to complete the labelling procedure.

The disc name lights up in the display.



Repeat Steps 2 to 7 to label other discs.

Note

- The disc title stores the number of the slot in which the CD was inserted. Rewrite the disc title when inserting a new CD into that slot.

To erase a disc name

1 Follow Steps 2 and 3 in “Labeling a CD” on page 26 to select the disc name you want to erase.

2 Press CLEAR.
The disc title disappears.

3 Press ENTER.

Erasing all titles of all discs

While holding down LOOP/DELETE, press CLEAR. “ALL ERASE” appears in the display, and all disc titles will be erased.

Tips

- When you replace a disc with a CD-TEXT disc, the disc title of the CD-TEXT disc is restored automatically.
The disc title for the CD-TEXT disc is no longer stored when the CD is removed.
Note that you cannot change the disc title of the CD-TEXT disc.
- You can label discs while the front cover is open.

Locating a specific CD

(for MHC-F100/MHC-FR1 only)

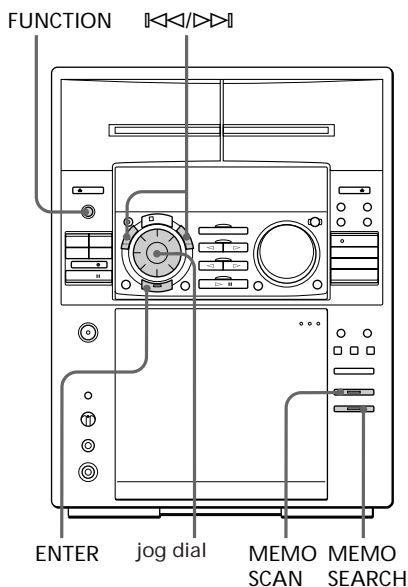

Locating a disc by scanning each disc title

— Memo Scan

You can locate a disc you want to play quickly by scanning the disc title (see page 26) in the display and start playing.

Note that you cannot use this function in the ALL DISCS Shuffle Play mode.

- 1 Press **FUNCTION** repeatedly until “CD” appears.
- 2 Press **MEMO SCAN**.
“MEMO SCAN” appears, and the lamp on the **ENTER** button flashes.
Disc titles will appear in order.

- 3 Press **ENTER** when the disc title of the disc you want to play appears.
The disc is set to the playing position, and the player starts playing.
In Program Play mode, the disc will be added to the end of the program.

Note

If “NO ENTRY” appears, no disc has been labeled. Try the Memo Scan function again after labeling the discs.

Locating a disc by searching a specific disc title

— Memo Search

You can search and locate a disc you want by inputting the first character used in the disc title (see page 26).

- 1 Press **FUNCTION** repeatedly until “CD” appears.
- 2 Press **MEMO SEARCH** (or **SEARCH** on the remote).
“MEMO SEARCH” appears and the lamp on the **ENTER** button flashes.
- 3 Press **◀◀/▶▶** repeatedly to input the first character.



Each time you press **◀◀/▶▶**, the characters appear in the following order.

A B C D E F G H I J K L M N O P Q R S T
U V W X Y Z 0 1 2 3 4 5 6 7 8 9

If “[A] NOT FOUND” appears in the display while inputting the first character with the **◀◀/▶▶** buttons, no disc has been labeled using the input character.

Notes

- When searching input characters, blanks and symbols before the first character in the Disc Memo are ignored.
- When searching input characters, upper and lower cases cannot be differentiated.

4 Turn the jog dial to find the disc title you want.

As you turn the jog dial, the Disc Memos starting with the input character appear in the display.

5 Press ENTER to select the disc.

In Program Play mode, the disc will be added to the end of the program.

To locate a disc on the remote

Press the ◀ or ▶ key on the remote until the disc title in step 4 that you want appears. Skip step 5.

To cancel Memo Search

Press MEMO SEARCH again.

Tips

- If there is no more disc title starting with the input character in Step 4, the input character changes to the next one when you turn the jog dial.

Playing highlights of the CD

(for MHC-F100/MHC-FR1 only)

Some CD-TEXT discs have a feature to play only the highlights of the discs.

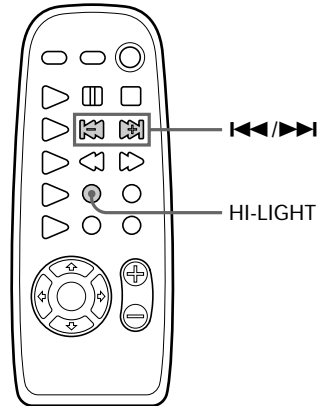

➔ Press HI-LIGHT on the remote in the stop mode.

The indicator on the ▷ button flashes while playing disc highlights.

Tips

- During play of disc highlights, you can return to normal play by pressing ◀◀/▶▶ on the remote.
- During play of disc highlights, you can move to an earlier or later highlight song by pressing ◀◀/▶▶ on the remote.
- During play of disc highlights, you can use Repeat Play function.
To repeat all the highlight songs, keep pressing REPEAT until "REPEAT" appears.
To repeat only the current highlight song, keep pressing REPEAT until "REPEAT 1" appears.
- If you press HI-LIGHT while selecting discs without this feature, "NO HIGHLIGHT" appears in the display.

Recording on a tape manually

You can record from CD, tape, or radio as you like. For example, you can record just the songs you want or record from the middle of the tape. The recording level is adjusted automatically.

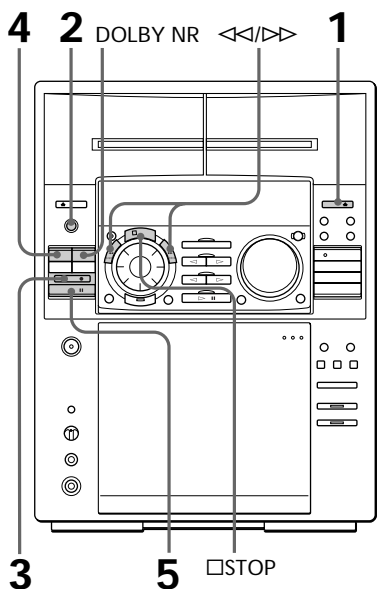

1 Insert a blank tape into deck B.

2 Press FUNCTION repeatedly until the source you want to record (e.g., CD) appears.

3 Press REC ○.
Deck B stands by for recording. ▷ (for front side) lights up.

4 Press DIRECTION repeatedly to select ⇄ to record on one side. Select ⇄ (or RELAY) to record on both sides.

5 Press PAUSE □□.
Recording starts.

6 Start playing the source to be recorded.

To	Press
Stop recording	□ STOP
Pause recording	PAUSE □□

Tips

- If you want to record from the reverse side, press TAPE B ◀ so that ◀ (for reverse side) lights up.
- When you want to reduce the hiss noise in low-level high-frequency signals, press DOLBY NR so that "DOLBY NR B" appears before step 5.

Note

- Pressing FUNCTION with "TAPE B" selected starts silent recording (blank recording).

Recording a CD by specifying track order

You can record tracks from all the CDs in the order you want. When programming, make sure the playing times for each side do not exceed the length of the tape.

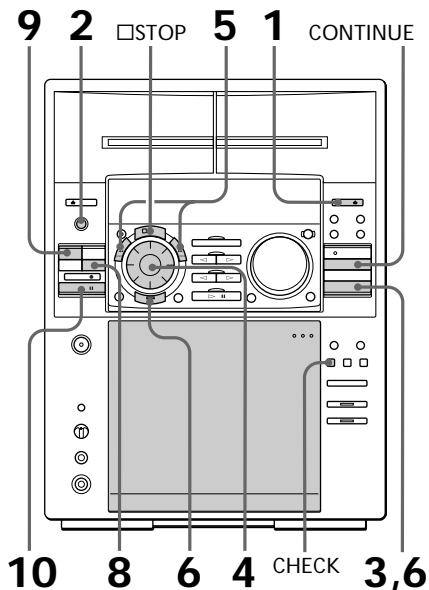

- 1** Insert a blank tape into deck B.
- 2** Press FUNCTION repeatedly until "CD" appears.
- 3** Press PROGRAM repeatedly until the program number (PROGRAM 1, 2 or 3) appears.
- 4** Turn the jog dial until the disc number you want appears.

- 5** To program a whole disc, skip this step.
Press \lll / \ggg until the desired track appears in the display.

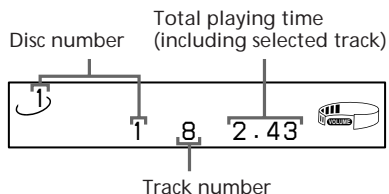

- 6** Press ENTER or PROGRAM.
The track is programmed.

To program	Repeat Steps
Other discs	4 and 6
Other tracks on the same disc	5 and 6
Other tracks on other discs	4 to 6

- 7** To program additional tracks to be recorded, repeat steps 4 to 6.
Skip step 4 to select tracks from the same disc.

- 8** Press CD SYNCHRO.
Deck B stands by for recording and the CD player stands by for playback. \blacktriangleright (for front side) lights up.

- 9** Press DIRECTION repeatedly to select \rightleftarrows to record on one side.
Select \leftrightarrow (or RELAY) to record on both sides.

- 10** Press PAUSE $\square\square$.
Recording starts.

continued

Recording a CD by specifying track order (continued)

To stop recording

Press STOP.

To check the order

Press CHECK repeatedly. After the last track, "END" appears.

To cancel Program Edit

Press CONTINUE.

Tip

If the track cuts off during recording, because the tape ended while recording on the A side, the track will automatically be recorded from the beginning on the B side.

Looping part of a CD

— Loop

With the loop function, you can repeat part of a CD during playback. This lets you create original recordings.

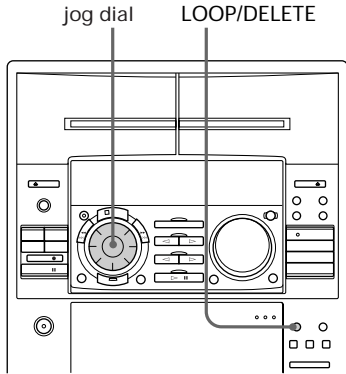

➔ Press and hold LOOP/DELETE during playback at the point you want to start the Loop function, and release to resume normal play.

To adjust the loop length

Turn the jog dial while holding LOOP/DELETE (or press ◀ or ▶ while holding LOOP/DELETE on the remote) to select different loop lengths (LOOP 1 – 20).

Flashing part of a CD

— Flash

With the flash function, you can “flash” the CD sound during playback. This lets you create original recordings.

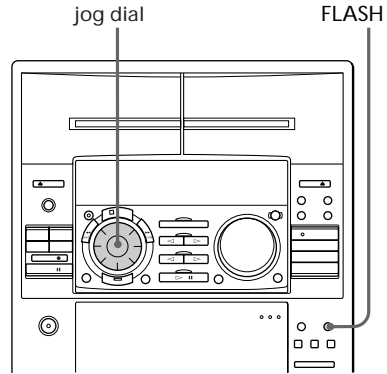

➔ Press and hold FLASH during playback at the point you want to start the Flash function, and release to resume normal play.

To adjust the flash length

Turn the jog dial while holding FLASH to select different flash lengths (FLASH 1 – 20).

To adjust the flash length on the remote, press ◀ or ▶ while holding FLASH. (For MHC-F50 only)

To use LOOP and FLASH together

Press and hold both LOOP and FLASH at the same time.

Notes

- The loop and flash length cannot be adjusted during this operation. Adjust the loop and flash lengths independently beforehand if necessary.
- To record the flash effect, use the analog (VIDEO/MD OUT) connections or this unit's tape deck.

Adjusting the sound

You can reinforce the bass, create a more powerful sound, and listen with headphones.

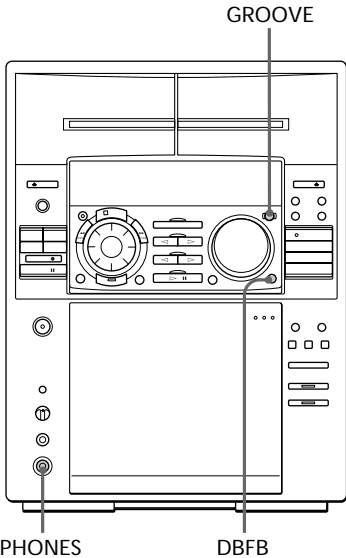

Notes

- With some songs, the music will sound distorted when you use the DBFB system with the graphic equalizer if the bass is too strong. Adjust the bass slowly while listening to music so that you can monitor the effect of the adjustment.
- Cancelling GROOVE sets DBFB to “DBFB ███” and flattens the equalizer curve. To cancel the DBFB level, press DBFB until the indication disappears. Adjust the equalization to obtain the effect you desire.

To listen through the headphones

Connect the headphones to PHONES jack. No sound will come from the speakers.

Note

If you have connected a super woofer, please note that sound comes from the super woofer even when the headphones are connected. Turn off the power of the super woofer when using headphones. (Except for MHC-F50)

To reinforce bass (DBFB)

Press DBFB*.

Each time you press the button, the display changes as follows:

DBFB ███ → DBFB █████ → display off



“DBFB █████” is more effective than “DBFB ███”.

* DBFB = Dynamic Bass Feedback

For a powerful sound (GROOVE)

Press GROOVE. The volume switches to power mode, DBFB is automatically set to full strength, the equalizer curve changes, and the “GROOVE” button lights up. Press GROOVE again to return to the previous volume.

Selecting the audio emphasis

The audio emphasis menu lets you select the sound characteristic according to the sound you are listening to.

The personal file function (see “Making a personal audio emphasis file”) lets you store your own effects.

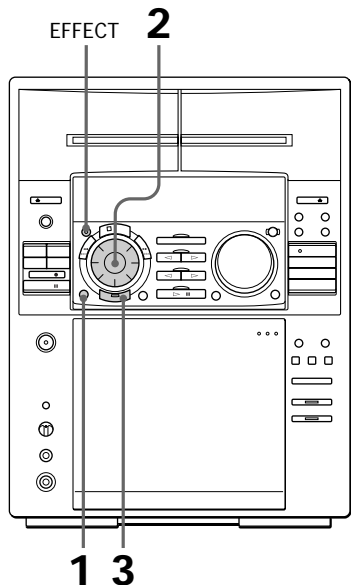

- 1** Press **GEQ FILE** on the unit repeatedly until effect name appears.
- 2** Use the jog dial (or press **GEQ FILE** for MHC-F100/MHC-FR1 or **GEQ FILE +/-** for MHC-F50 on the remote) to select the desired music menu.
The preset name appears in the display. See the chart “Music menu options” on this page. The last effect chosen from that menu appears.
- 3** Press **ENTER**.
You don’t need to press **ENTER** when you use the remote.

To cancel the effect

Press **EFFECT** repeatedly so that “**EFFECT OFF**” appears in the display.

Music menu options

“**SUR** [|||||]” appears if you select an effect with surround effects.

Effect	For
1 ROCK	Standard music sources
2 POP	
3 JAZZ	
4 DANCE	
5 SOUL	
6 ACTION	Soundtracks and special listening situations
7 ROMANCE	
8 SF	
9 DRAMA	
10 SPORTS	Video games
11 SHOOTING	
12 RACING	
13 RPG	
14 BATTLE	
15 ADVENTURE	Personal audio emphasis file (see page 38)
P FILE 1 – 5	

continued

Selecting the audio emphasis (continued)

To change the equalizer display

Each time you press SPECTRUM ANALYZER, the equalizer display changes to show one of the three displays below.

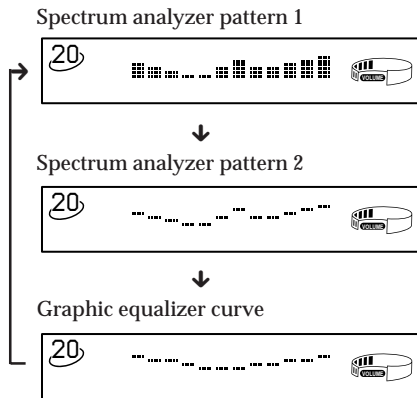

Adjusting the audio emphasis

You can adjust the audio emphasis using the graphic equalizer and surround effect.

To enjoy the sound with the adjusted equalizer and surround effect at the same time, do the procedure “Adjusting the graphic equalizer” first.

Adjusting the graphic equalizer

You can adjust the sound by raising or lowering the levels of specific frequency ranges.

Before operation, first select the audio emphasis you want for your basic sound.

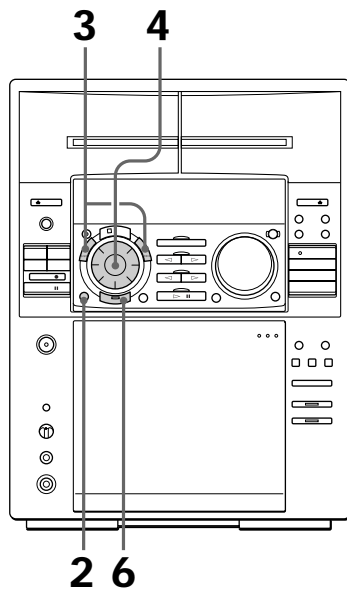

- 1 Select the audio emphasis you want for your basic sound (see “Selecting the audio emphasis”).

2 Press GEQ FILE on the unit repeatedly until the graphic equalizer appears.

3 Press +/- repeatedly to select a frequency band.



4 Turn the jog dial to adjust level.

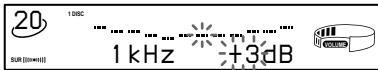

5 Repeat steps 3 and 4.

6 Press ENTER when finished.

Note

If you choose another menu audio emphasis (other than "EFFECT OFF") the adjusted sound effect is lost. To retain the adjusted sound effect for future use, store it in a personal file. (See "Making a personal audio emphasis file".)

Activating the surround effect

You can enjoy the surround effect.

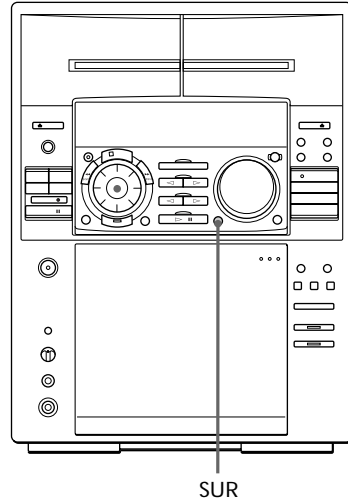

➔ Press SUR repeatedly so that "SUR (|||||)" appears in the display.

Note

When you choose other sound effects, the surround effects will be canceled. If you want to memorize the effect, store it into a personal file (see "Making a personal audio emphasis file").

Making a personal audio emphasis file

— Personal file

You can create a personal file of audio patterns (surround effect and graphic equalizer) and store them in the memory of the unit. Later call up an audio pattern to play a favorite tape, CD, or radio program. Create up to five audio files.

Before operation, first select the audio emphasis you want for your basic sound.

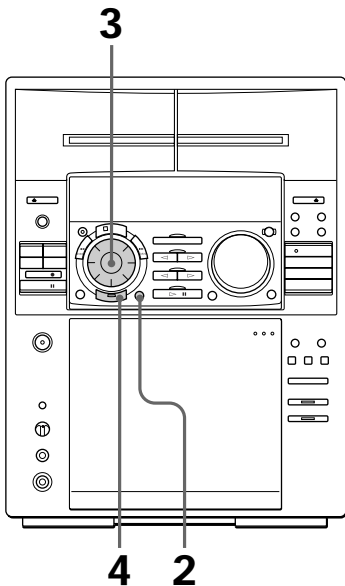

1 Obtain the sound effect you want by using graphic equalizer (page 36) and the surround effect (page 37).

2 Press GEQ MEMO.
The personal file number appears in the display.

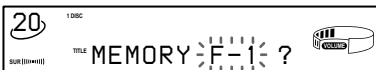

3 Use the jog dial to select the file number (FILE 1 - 5) where you want to store the sound effect.

4 Press ENTER.
The adjusted sound effects are stored under the selected file number. The settings previously stored at this memory location are erased and replaced by the new settings.

To call up the personal file

- 1** Press GEQ FILE on the unit to display the last selected personal file.
- 2** Use the jog dial (or press GEQ FILE for MHC-F100/MHC-FR1 or GEQ FILE +/- for MHC-F50 on the remote) to select the desired file number (FILE 1 - 5).
- 3** Press ENTER.
You don't need to press ENTER when you use the remote.

Singing along: Karaoke

(For Singaporean model only)

You can sing along with any stereo CD or tape by turning down the singer's voice. You need to connect an optional microphone.

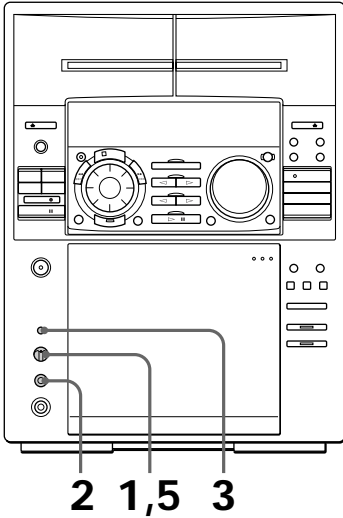

1 Turn MIC LEVEL to 0 to turn down the microphone control level.

2 Connect an optional microphone to MIX MIC.

3 Press KARAOKE PON/MPX repeatedly to obtain the karaoke effect you desire.

Every time you press the button, the display changes as follows:

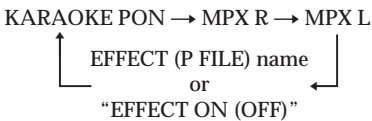

The indicator appears in the display when a karaoke mode is activated.

To sing karaoke with decreasing the vocal level of a CD, select KARAOKE PON. To sing karaoke of multiplex CD or tape, select MPX R or MPX L.

4 Start playing the music and adjust the volume.

5 Adjust the microphone volume by turning MIC LEVEL.

When you are done

Turn MIC LEVEL to 0 and disconnect the microphone from MIX MIC, then press KARAOKE PON/MPX repeatedly so that disappears.

Mixing and recording sounds

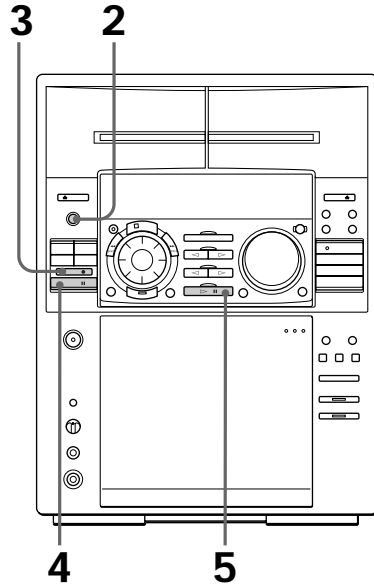

1 Do the above steps 1 to 5. Then, insert a tape in deck B.

Singing along: Karaoke (continued)

- 2 Press FUNCTION repeatedly to select the source you desire and set it to pause mode.
- 3 Press REC ○.
- 4 Press PAUSE □□.
- 5 Press CD ▷ to start playing the CD player (or TAPE ▷).
Playback starts. Start singing along with the music.

To stop recording

Press □ STOP.

Tips

- If acoustic feedback (howling) occurs, move the microphone away from the speakers or change the direction of the microphone.
- If you want to record your voice through the microphone only, you can do so by selecting the CD function and not playing a CD.

Notes

- Karaoke mode is cancelled if:
 - you press EFFECT or a sound effect
 - you press FUNCTION
 - you turn off the power
- The instrumental sound may be reduced as well as the singer's voice when the sound is recorded in monaural.
- The singer's voice may not be reduced when:
 - only a few instruments are playing
 - a duet is being played
 - the source has strong echoes or chorus
 - the singer's voice deviates from the center.
 - the voice on the source is singing in high soprano or tenor.

Falling asleep to music

— Sleep Timer

You can let the system turn off at the preset time by using the remote, so you can sleep to the music. You can preset the time to be turned off by 10 minutes.

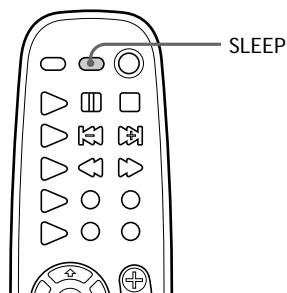

➔ Press SLEEP on the remote.

Every time you press the button, the minute display (the turn-off time) changes as follows:

AUTO → 90min → 80min → 70min
→ ... → 10min → OFF → AUTO ...

When you choose auto

The power turns off when the current CD or tape finishes playback (for up to 100 minutes).

To check the remaining time

Press SLEEP once.

To change the time to turn off

Select the time you want by pressing SLEEP repeatedly.

To cancel the Sleep Timer function

Press SLEEP repeatedly until "OFF" appears.

Waking up to music

— Wake-up Timer

You can wake up to music at a preset time every day. Make sure you have set the clock (see “Step 2: Setting the time”).

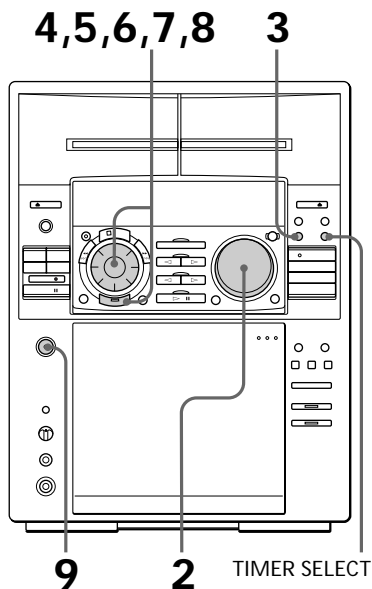

1 Prepare the music source you want to play.

- CD: Insert a CD. To start from a specific track, make a program (see “Programming the CD tracks”).
- Tape: Insert a tape with the side you want to play facing forward. When both decks A and B have tapes in them, play will start from deck A.
- Radio: Tune in the preset station you want (see “Step 3: Presetting radio stations”).

2 Adjust the volume.

3 Press \odot /CLOCK SET.
“SET DAILY 1” appears.

4 Turn the jog dial to select DAILY 1 or 2, then press ENTER.
“ON” appears and the hour digits flash in the display.

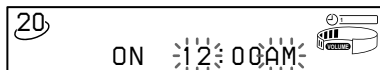

5 Set the time to start playback.
Turn the jog dial to set the hour, then press ENTER.
The minute indication starts flashing.

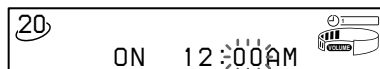

Turn the jog dial to set the minute, then press ENTER.
The hour indication flashes again.

6 Set the time to stop playback following the above procedure.

7 Turn the jog dial until the music source you want appears.
The indications change as follows:
TUNER ↔ CD PLAY ↔ TAPE PLAY

8 Press ENTER.
The start time, followed by the stop time and the music source, appears, then the original display appears.

9 Turn off the power.

continued

Waking up to music (continued)

To check the setting

Press **TIMER SELECT** and turn the jog dial to select the respective mode (DAILY 1 or DAILY 2), then press **ENTER**. To change the setting, start over from step 1.

To cancel the timer operation

Press **TIMER SELECT** and turn the jog dial to select "OFF", then press **ENTER**.

Tip

The power turns on 15 seconds before the preset time.

Timer-recording radio programs

To timer-record, you must preset the radio station (see "Step 3: Presetting radio stations") and set the clock (see "Step 2: Setting the time") beforehand.

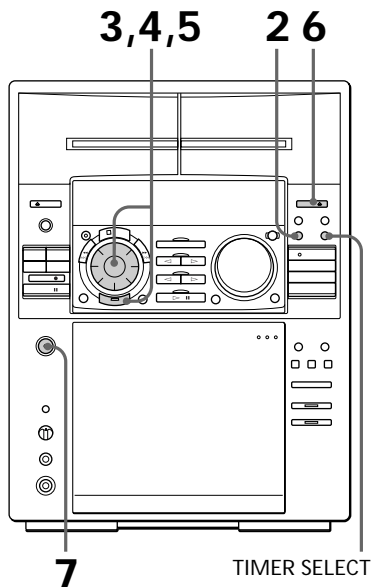

- 1 Tune in the preset radio station (see "Listening to the radio").
- 2 Press **⊖/CLOCK SET**.
"SET DAILY 1" appears.
- 3 Turn the jog dial to select **REC**, then press **ENTER**.
"ON" appears and the hour digits flash in the display.

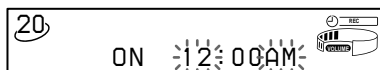

4 Set the time to start recording.

Turn the jog dial to set the hour, then press ENTER.

The minute indication starts flashing.

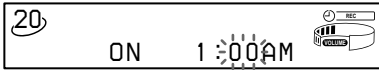

Turn the jog dial to set the minute, then press ENTER.

The hour indication flashes again.

5 Set the time to stop recording following the above procedure.

The start time appears, followed by the stop time, the recording source and the radio station, then the original display appears.

6 Insert a blank tape into deck B.

7 Turn off the power.

When the recording starts, the volume level is set to the minimum.

To check the setting

Press TIMER SELECT and turn the jog dial to select "REC", then press ENTER. To change the setting, start over from step 1.

To cancel the timer operation

Press TIMER SELECT and turn the jog dial to select "OFF", then press ENTER.

Note

If the power is on at the preset time, the recording will not be made.

Precautions

On operating voltage

Before operating the system, check that the operating voltage of your system is identical with the voltage of your local power supply.

On safety

- The unit is not disconnected from the AC power source (mains) as long as it is connected to the wall outlet, even if the unit itself has been turned off.
- Unplug the system from the wall outlet (mains) if it is not to be used for an extended period of time. To disconnect the cord (mains lead), pull it out by the plug. Never pull the cord itself.
- Should any solid object or liquid fall into the component, unplug the stereo system and have the component checked by qualified personnel before operating it any further.
- The AC power cord must be changed only at the qualified service shop.

On placement

- Place the stereo system in a location with adequate ventilation to prevent heat build-up in the stereo system.
- Do not place the unit in an inclined position.
- Do not place the unit in locations where it is;
 - Extremely hot or cold
 - Dusty or dirty
 - Very humid
 - Vibrating
 - Subject to direct sunlight

On operation

- If the stereo system is brought directly from a cold to a warm location, or is placed in a very damp room, moisture may condense on the lens inside the CD player. Should this occur, the system will not operate properly. Leave the system turned on for about an hour until the moisture evaporates.
- When you move the system, take out any discs.

If you have any questions or problems concerning your stereo system, please consult your nearest Sony dealer.

Notes on CDs

- Before playing, clean the CD with a cleaning cloth. Wipe the CD from the center out.
- Do not use solvents such as benzene, thinner, commercially available cleaners or anti-static spray intended for vinyl LPs.
- Do not expose the CD to direct sunlight or heat sources such as hot air ducts, nor leave it in a car parked in direct sunlight.

Cleaning the cabinet

Use a soft cloth slightly moistened with mild detergent solution.

To save a tape permanently

To prevent a tape from being accidentally recorded over, break off the cassette tab from side A or B as illustrated. If you later want to reuse the tape for recording, cover the broken tab with adhesive tape.

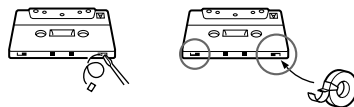

When you are using a TYPE II (CrO₂) or TYPE IV (metal, for playback only) cassette, be careful not to cover the detector slots which allow the tape player to automatically detect the type of tape.

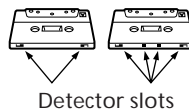

Before placing a cassette in the tape deck

Take up any slack in the tape. Otherwise the tape may get entangled in the parts of the tape deck and become damaged.

When using a tape longer than 90 minutes

The tape is very elastic. Do not change the tape operations such as play, stop, and fast-winding etc. frequently. The tape may get entangled in the tape deck.

Cleaning the tape heads

Clean the tape heads after every 10 hours of use.

When the tape heads become dirty

- the sound is distorted
- there is a decrease in sound level
- the sound drops out
- the tape does not erase completely
- the tape does not record

Make sure to clean the tape heads before you start an important recording or after playing an old tape. Use separately sold dry-type or wet-type cleaning cassette. For details, refer to the instructions of the cleaning cassette.

Demagnetizing the tape heads

Demagnetize the tape heads and the metal parts that have contact with the tape every 20 to 30 hours of use with a separately sold demagnetizing cassette.

For details, refer to the instructions of the demagnetizing cassette.

Troubleshooting

If you run into any problem using this stereo system, use the following check list.

First, check that the power cord is connected firmly and the speakers are connected correctly and firmly.

Should any problem persist, consult your nearest Sony dealer.

General

The display starts flashing as soon as you plug in the power cord even though you haven't turned on the power (demonstration mode).

- Press DISPLAY/DEMO when the power is turned off.

The demonstration mode appears automatically the first time you plug in the power cord. If there is a power outage lasting longer than half a day, redo the following:

- Clock setting (see "Step 2: Setting the time")
- Preset stations (see "Step 3: Presetting radio stations")
- Timer settings (see "Waking up to music" and "Timer recording radio programs").

"12:00 AM" flashes in the display.

- A power interruption occurred. Set the clock and timer settings again.

There is no sound.

- Rotate VOLUME clockwise.
- The headphones are connected.
- Insert only the stripped portion of the speaker cord into the SPEAKER jack. Inserting the vinyl portion of the speaker cord will obstruct the speaker connections.

continued

Troubleshooting (continued)

There is severe hum or noise.

- A TV or VCR is placed too close to the stereo system. Move the stereo system away from the TV or VCR.
-

The sound from the connected source is distorted.

- If "VIDEO" appears in the display when you press FUNCTION, switch the display to "MD" (see "Before connecting an MD deck" on page 10).
-

The timer does not function.

- Set the clock correctly.
-

DAILY1, DAILY 2, and REC do not appear when you press the TIMER SELECT button.

- Set the timer correctly.
 - Set the clock.
-

The remote does not function.

- There is an obstacle between the remote and the system.
 - The remote is not pointing in the direction of the system's sensor.
 - The batteries have run down. Replace the batteries.
-

There is acoustic feedback.

- Decrease the volume level.
 - Move the microphone away from the speakers or change the direction of the microphone.
-

The color irregularity on a TV screen persists.

- Place the speakers farther away from the TV set.
-

Speakers

Sound comes from one channel or unbalanced left and right volume.

- Check the speaker connection and speaker placement.
-

There is no sound from the surround speakers (for MHC-F100/MHC-FR1 only).

- Connect the left and right surround speakers correctly.
 - Press SUR to turn on the surround effect.
-

CD Player

The CD will not play.

- Close the front cover.
 - Check if the CD is correctly inserted in the slot.
 - The CD is dirty.
 - The CD is inserted label side left.
 - Moisture condensation has built up. Leave the system turned on for about an hour until the moisture evaporates.
-

Play does not start from the first track.

- The player is in program or shuffle mode. Press CONTINUE.
-

"OVER" is displayed.

- You have reached the end of the CD. Press **◀◀** (or press and hold **◀◀** on the remote) to return.
-

Tape Deck

The tape does not record.

- No tape in the cassette holder.
- The tab has been removed from the cassette (see “To save a tape permanently” on page 44).
- The tape has reeled to the end.

The tape does not record nor play or there is a decrease in sound level.

- The heads are dirty. Clean them (see “Cleaning the tape heads” on page 45).
- The record/playback heads are magnetized. Demagnetize them (see “Demagnetizing the tape heads” on page 45).

The tape does not erase completely.

- The record/playback heads are magnetized. Demagnetize them (see “Demagnetizing the tape heads” on page 45).

There is excessive wow or flutter, or the sound drops out.

- The capstans or pinch rollers are dirty. Clean them (see “Cleaning the tape heads” on page 45).

Noise increases or the high frequencies are erased.

- The record/playback heads are magnetized. Demagnetize them (see “Demagnetizing the tape heads” on page 45).
-

Tuner

Severe hum or noise (“TUNED” or “STEREO” flashes in the display).

- Adjust the antenna.
- The signal strength is too weak. Connect the external antenna.

A stereo FM program cannot be received in stereo.

- Press STEREO/MONO so that “STEREO” appears.
-

If other troubles not described above occur, reset the system as follows:

- 1 Unplug the power cord.
- 2 Plug the power cord back in.
- 3 Press FUNCTION, ENTER, and CD PLUS ONE at the same time.

The system is all reset. Restore all settings you did.

Specifications

For the U.S. model

AUDIO POWER SPECIFICATIONS

POWER OUTPUT AND TOTAL HARMONIC DISTORTION:

With 8 ohm loads (6 ohms loads for MHC-F50), both channels driven, from 70 – 20,000 Hz; rated 100 watts (50 watts for MHC-F50) per channel minimum RMS power, with no more than 0.9% total harmonic distortion from 250 milliwatts to rated output.

Amplifier section

Continuous RMS power output

Canadian model 100 + 100 watts
(8 ohms at 1 kHz,
5% THD) (for MHC-F100)

60 + 60 watts
(6 ohms at 1 kHz,
5% THD) (for MHC-F50)

Other models 100 + 100 watts
(8 ohms at 1 kHz,
10% THD)

Peak music power output (except for U.S. and Canadian models): 1400 watts

Inputs VIDEO/MD IN (phono jacks): voltage 250 mV, impedance 47 kilohms
MIX MIC (phone jack) (for Singaporian model only): sensitivity 1 mV, impedance 10 kilohms

Outputs VIDEO/MD OUT (phono jacks): voltage 250 mV impedance 1 kilohms
PHONES (stereo phone jack): accepts headphones of 8 ohms or more.
SPEAKER: accepts impedance of 8 to 16 ohms (for MHC-F100/MHC-FR1 only)
accepts impedance of 6 to 16 ohms (other models)
SURROUND SPEAKER (for MHC-F100/MHC-FR1 only): accepts impedance of 16 ohms.
SUPER WOOFER (for MHC-F100/MHC-FR1 only): Voltage 1 V, impedance 1 kilo ohm

CD player section

System	Compact disc and digital audio system
Laser	Semiconductor laser ($\lambda=780\text{nm}$) Emission duration: continuous
Laser output	Max. 44.6 μW^* *This output is the value measured at a distance of 200 mm from the objective lens surface on the Optical Pick-up Block with 7 mm aperture.
Wavelength	780 – 790 nm
CD OPTICAL DIGITAL OUT	
(Square optical connector jack, rear panel) (for MHC-F100/MHC-FR1 only)	
Wavelength	600 nm

Tapc player section

Recording system	4-track 2-channel stereo
Frequency response (DOLBY NR OFF)	60 – 13,000 Hz (± 3 dB), using Sony TYPE I cassette 60 – 14,000 Hz (± 3 dB), using Sony TYPE II cassette
Wow and flutter	$\pm 0.15\%$ W.Peak (IEC) 0.1% W.RMS (NAB) $\pm 0.2\%$ W.Peak (DIN)

Tuner section

FM stereo, FM/AM superheterodyne tuner

FM tuner section

Tuning range 87.5 – 108.0 MHz
Antenna terminals 75 ohm unbalanced
Intermediate frequency 10.7 MHz

AM tuner section

Tuning range
North American models: 530 – 1,710 kHz
(with the AM tuning interval set at 10 kHz)
531 – 1,710 kHz
(with the AM tuning interval set at 9 kHz)
Singaporian model: MW
531 – 1,602 kHz
(with the MW tuning interval set at 9 kHz)
530 – 1,710 kHz
(with the MW tuning interval set at 10 kHz)
SW
5.95 – 17.90 MHz
(with the SW tuning interval set at 5 kHz)
Other models: 531 – 1,602 kHz
(with the AM tuning interval set at 9 kHz)
530 – 1,710 kHz
(with the AM tuning interval set at 10 kHz)
Intermediate frequency 450 kHz
Antenna AM loop antenna
External antenna terminal

Speaker

SS-F100 (for MHC-F100/MHC-FR1)

SS-F50 (for MHC-F50)

Speaker system 3-way, 3-unit, bass-reflex type
Speaker units
Woofer: 17 cm, cone type
Tweeter: 5 cm, cone type
Super Tweeter: 2 cm, dome type
Nominal impedance 8 ohms (SS-F100)
6 ohms (SS-F50)
Dimensions (w/h/d) Approx. 215 x 375 x 285 mm
Mass Approx. 4.5 kg net per speaker

General

Power requirements

North American models: 120 V AC, 60 Hz
Australian models: 220-240 V AC, 50/60 Hz
Other models: 110-120 V or 220-240 V AC, 50/60 Hz Adjustable with voltage selector

Power consumption

U.S. model: 195 watts (MHC-F100)
110 watts (MHC-F50)
Canadian model: 195 watts (MHC-F100)
120 watts (MHC-F50)

Other models:

210 watts
Dimensions (w/h/d) Approx. 280 x 375 x 450 mm

Mass

Approx. 11.5 kg (MHC-F100/MHC-FR1)
Approx. 10 kg (MHC-F50)

Supplied accessories:

AM loop antenna (1)
Remote (1)
RM-SF100 for MHC-F100/MHC-FR1
RM-SF50 for MHC-F50
Sony SUM-3 (NS) batteries (2)
FM lead antenna (1)
Speaker cords (2)

Optional accessory (for MHC-F100 Canadian Model only):

Surround speaker SS-SR101
Speaker system 1-way, 1-unit, bass-reflex type

Speaker units

Full range 8 cm, cone type
Nominal impedance 16 ohms
Dimensions (w/h/d) Approx. 205 x 95 x 240 mm
Mass Approx. 1.1 kg net per speaker

Design and specifications are subject to change without notice.

Index

A

- Adjusting
 - the audio emphasis 36
 - the sound 34
 - the volume 13, 16
- Antennas 4, 12

B

- Batteries 5

C

- CD player 13
- CD Synchro Recording 15
- Clock setting 6
- Connecting. *See* Hooking up

D, E

- Disc Memo 26
- Display 21, 36

F, G

- Flash 33

H

- High-speed Dubbing 20
- Hooking up
 - optional components 10
 - optional speakers 11
 - the antennas 4, 12
 - the power 5
 - the system 4

I, J, K

- Inserting CDs 8

L, M

- Loop 33

N

- Normal Play 13

O

- One Touch Play 14

P, Q

- Personal file 38
- Playing
 - a CD 13
 - a preset radio station 16
 - a tape 18
 - tracks in random order (Shuffle Play) 22
 - tracks in the desired order (Program Play) 23
 - tracks repeatedly (Repeat Play) 21
- Plus One Play 25
- Presetting radio stations 7
- Preset tuning 16
- Program Play 23
- Protecting recordings 44

R

- Radio stations
 - presetting 7
 - tuning in 16
- Recording
 - a CD 15
 - a radio program 17
 - a tape 20
 - timer recording 42
- Repeat Play 22
- Resetting the system 47

S

- Saving recordings 44
- Selecting the audio emphasis 35
- Setting the time 6
- Shuffle Play 22
- Sleep Timer 40
- Sound adjustment 34
- Speakers 4, 10, 11

T, U, V

- Timer
 - falling asleep to music 40
 - timer recording 42
 - waking up to music 41
- Troubleshooting 45
- Tuner 7, 16
- Tuning interval 7

W, X, Y, Z

- Wake-up timer 41

