

# *Mini Hi-Fi Component System*

---

## Operating Instructions

## Owner's Record

The model and serial numbers are located on the rear panel. Record the serial number in the space provided below. Refer to them whenever you call upon your Sony dealer regarding this product.

Model No. \_\_\_\_\_ Serial No. \_\_\_\_\_



## *MHC-GRX2 / MHC-RX33*

## WARNING

To prevent fire or shock hazard, do not expose the unit to rain or moisture.

To avoid electrical shock, do not open the cabinet. Refer servicing to qualified personnel only.

Do not install the appliance in a confined space, such as a bookcase or built-in cabinet.

Laser component in this product is capable of emitting radiation exceeding the limit for Class 1.

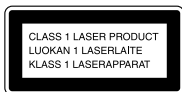

This appliance is classified as a CLASS 1 LASER product. The CLASS 1 LASER PRODUCT MARKING is located on the rear exterior.

This caution label is located inside the unit.

CAUTION	: INVISIBLE LASER RADIATION WHEN OPEN. AVOID EXPOSURE TO BEAM.
ADVARSEL	: USYNLIG LASERSTRÅLING VED ÅBNING NÅR SIKKERHEDSOPRINDERE ER UDE AF FUNKTION. UNDGÅ UDSÆTTELSE FOR STRÅLING.
VARO!	: AVATTAESSA JA SUOJALUKITUS OHITETTAESSA EIETÄ ALTUJIN LASERSTRÄLLE.
WARNING	: LASERSTRÅLING NÄR DENNA DEL ÄR ÖPPNAD OCH SPÄRREN ÄR URÖKPLAD.
ADVERSEL	: USYNLIG LASERSTRÅLING NÄR DEKSEL APNES UNGÅ EKSPOSERING FOR STRÅLEN.

## NOTICE FOR THE CUSTOMERS IN THE U.S.A.

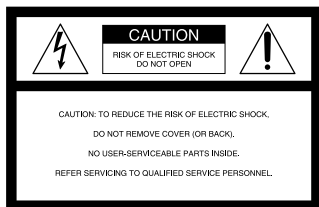

This symbol is intended to alert the user to the presence of uninsulated “dangerous voltage” within the product’s enclosure that may be of sufficient magnitude to constitute a risk of electric shock to persons.



This symbol is intended to alert the user to the presence of important operating and maintenance (servicing) instructions in the literature accompanying the appliance.

## CAUTION

The use of optical instruments with this product will increase eye hazard.

## INFORMATION

This equipment has been tested and found to comply with the limits for a Class B digital device, pursuant to Part 15 of the FCC Rules. These limits are designed to provide reasonable protection against harmful interference in a residential installation. This equipment generates, uses, and can radiate radio frequency energy and, if not installed and used in accordance with the instructions, may cause harmful interference to radio communications. However, there is no guarantee that interference will not occur in a particular installation. If this equipment does cause harmful interference to radio or television reception, which can be determined by turning the equipment off and on, the user is encouraged to try to correct the interference by one or more of the following measures:

- Reorient or relocate the receiving antenna.
- Increase the separation between the equipment and receiver.
- Connect the equipment into an outlet on a circuit different from that to which the receiver is connected.
- Consult the dealer or an experienced radio/TV technician for help.

## CAUTION

You are cautioned that any changes or modifications not expressly approved in this manual could void your authority to operate this equipment.

## Note on CATV system installer:

This reminder is provided to call CATV system installer’s attention to Article 820–40 of the NEC that provides guidelines for proper grounding and, in particular, specifies that the cable ground shall be connected to the grounding system of the building, as close to the point of cable entry as practical.

## NOTICE FOR THE CUSTOMERS IN CANADA

### CAUTION:

TO PREVENT ELECTRIC SHOCK, DO NOT USE THIS POLARIZED AC PLUG WITH AN EXTENSION CORD, RECEPTACLE OR OTHER OUTLET UNLESS THE BLADES CAN BE FULLY INSERTED TO PREVENT BLADE EXPOSURE.



(MHC-RX33 only)

---

# Table of Contents

---

## Getting Started

Step 1: Hooking up the system .....	4
Step 2: Setting the time .....	6
Step 3: Presetting radio stations .....	7
Connecting outdoor antennas .....	8

## Basic Operations

Playing a CD .....	9
Recording a CD .....	11
Listening to the radio .....	12
Recording from the radio .....	13
Playing a tape .....	14
Recording from a tape .....	15

---

## The CD Player

Using the CD display .....	16
Playing the CD tracks repeatedly .....	16
Playing the CD tracks in random order .....	17
Programming the CD tracks .....	18

---

## The Tape Deck

Recording CDs by specifying the track order .....	21
--	----

---

## Sound Adjustment

Adjusting the sound .....	23
Selecting the audio emphasis .....	23

---

## Other Features

Falling asleep to music .....	24
Waking up to music .....	24

---

## Additional Information

Precautions .....	26
Troubleshooting .....	27
Specifications .....	30
Index .....	back cover

## Step 1: Hooking up the system

Do the following procedure **1** to **4** to hook up your system using the supplied cords and accessories.

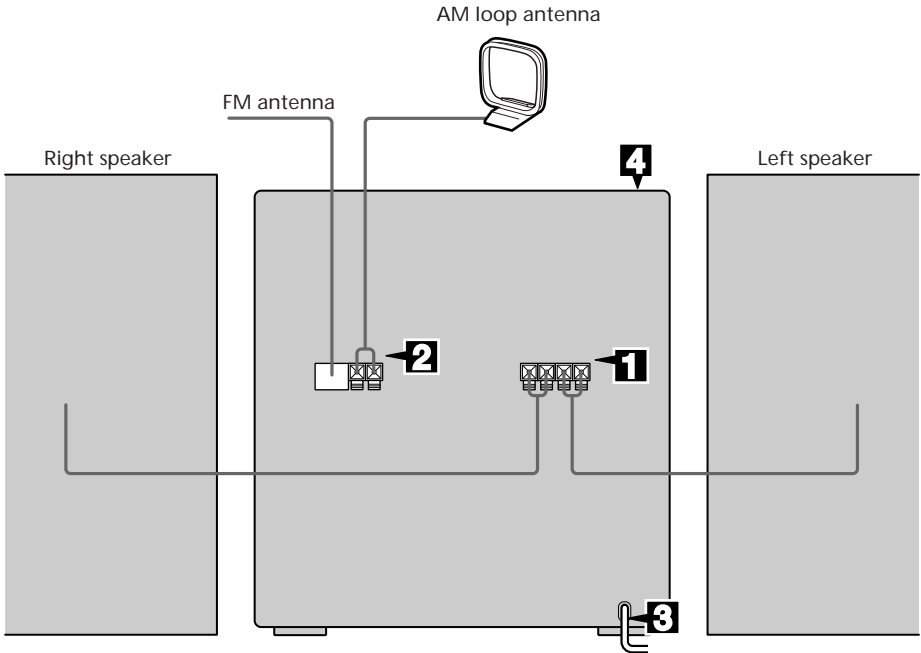

### **1** Connect the speakers.

Connect the speaker cords to the SPEAKER jacks of the same color. Keep the speaker cords away from the antennas to prevent noise.

Insert only the stripped portion.

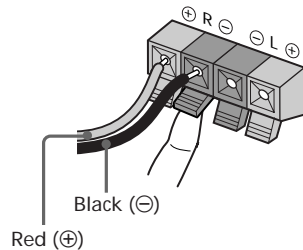

### **Note**

The type of supplied speakers varies according to the model you purchased (see "Specifications" on page 31).

- 
- 2** Connect the FM/AM antennas.  
Set up the AM loop antenna, then connect it.  
**Jack type ①**

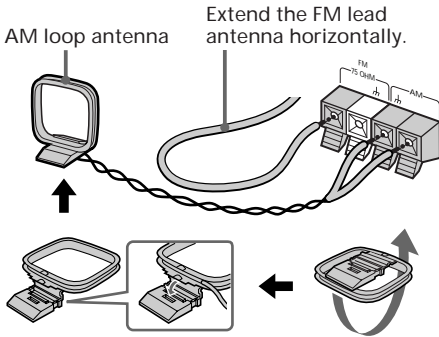

**Jack type ②**

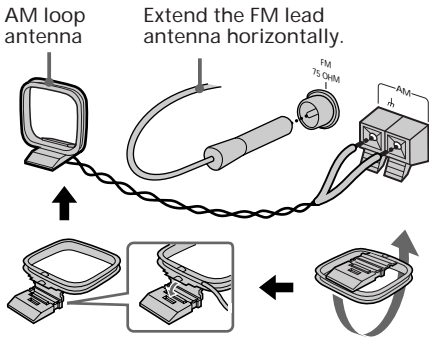

**Inserting two size AAA (R03) batteries into the remote**

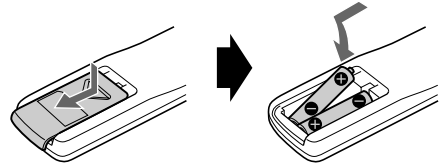

**Tip**

With normal use, the batteries should last for about six months. When the remote no longer operates the system, replace both batteries with new ones.

**Note**

If you do not use the remote for a long period of time, remove the batteries to avoid possible damage from battery leakage.

- 
- 3** Connect the power cord to a wall outlet.  
The demonstration appears in the display.

- 
- 4** Deactivate the demonstration mode by pressing DISPLAY/DEMO when the system power is turned off.  
The demonstration mode is also deactivated when you set the time.
-

---

## Step 2: Setting the time

You must set the time before using the timer functions.

You can set the time while the power is off.

For European models, the clock is on a 24-hour system.

For other models, the clock is on a 12-hour (AM/PM) system.

The 24-hour system model is used for illustration purposes.

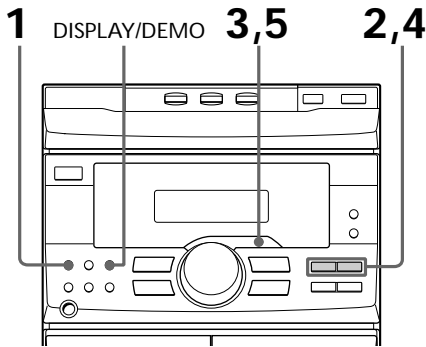

- 
- 1 Press **CLOCK/TIMER SET**.  
The hour indication flashes.



- 
- 2 Press **◀◀** or **▶▶** repeatedly to set the hour.



- 
- 3 Press **ENTER/NEXT**.  
The minute indication flashes.



- 
- 4 Press **◀◀** or **▶▶** repeatedly to set the minute.

- 
- 5 Press **ENTER/NEXT**.  
The clock starts working.
- 

### To change the preset time

You can also change the time while the power is on.

- 1 Press **CLOCK/TIMER SET**.
- 2 Press **◀◀** or **▶▶** repeatedly until "SET CLOCK" appears, then press **ENTER/NEXT**.
- 3 Repeat steps 2 to 5 in "Setting the time".

#### Tips

- If you've made a mistake, start over from step 1.
- Setting the time deactivates the demonstration mode.

If you want to display the demonstration mode, press **DISPLAY/DEMO** when the power is off.

## Step 3: Presetting radio stations

You can preset up to 30 stations, 20 for FM and 10 for AM.

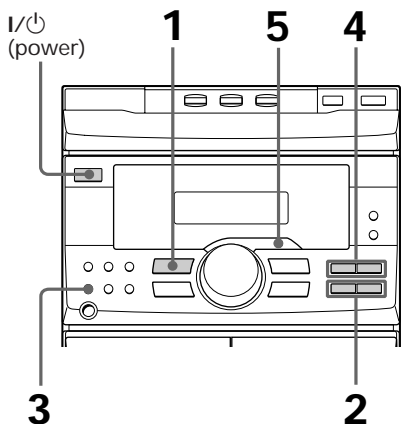

- 1 Press TUNER/BAND repeatedly until the band you want appears in the display.

Every time you press this button, the band changes as follows:  
FM ↔ AM

- 2 Press and hold ◀◀ or ▶▶ until the frequency indication starts to change automatically, then release it.

Scanning stops when the system tunes in a station. "TUNED" and "STEREO" (for a stereo program) appear.

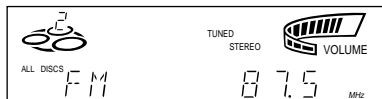

- 3 Press TUNER MEMORY.  
A preset number appears in the display.

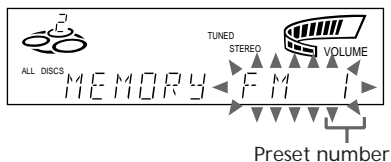

- 4 Press ◀◀ or ▶▶ repeatedly to select the preset number you want.
- 5 Press ENTER/NEXT.  
The station is stored.
- 6 Repeat steps 1 to 5 to store other stations.

### To tune in a station with a weak signal

When the desired station is skipped during automatic tuning, press ◀◀ or ▶▶ repeatedly in step 2 to tune in the station manually.

### To change the preset number

Start over from step 1.

### Tip

The preset stations are retained for half a day even if you unplug the power cord or if a power failure occurs.

# Connecting outdoor antennas

Connect the outdoor antenna to improve the reception.

## FM antenna

Connect the optional FM outdoor antenna. You can also use the TV antenna instead.

### Jack type ①

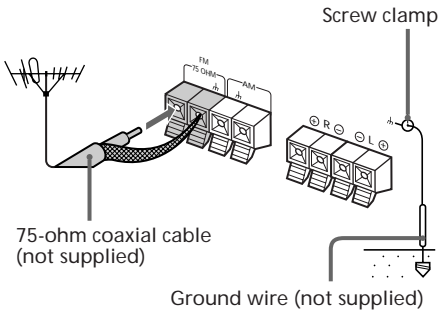

### Jack type ②

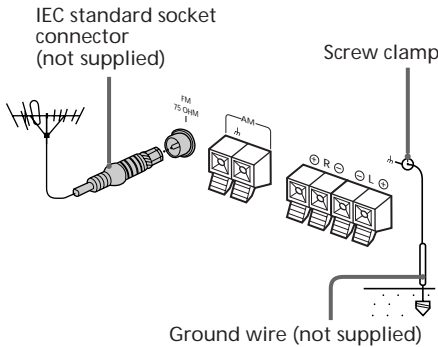

## AM antenna

Connect a 6- to 15- meter (20- to 50- feet) insulated wire to the AM antenna terminal. Leave the supplied AM loop antenna connected.

### Jack type ①

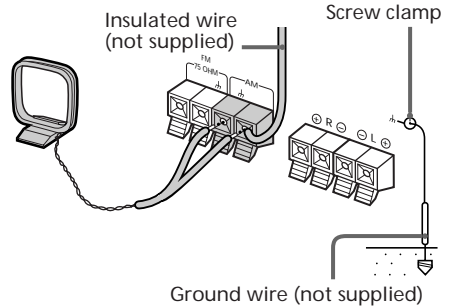

### Jack type ②

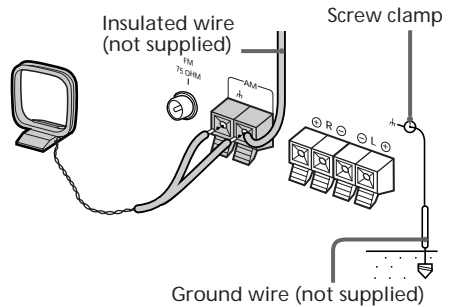

## Important

If you connect an outdoor antenna, ground from *h* terminal above the SPEAKER jacks with the screw clamp. To prevent a gas explosion, do not connect the ground wire to a gas pipe.



## Playing a CD

— Normal play

You can play up to three CDs in a row.

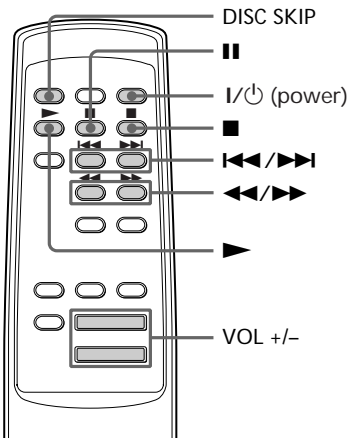
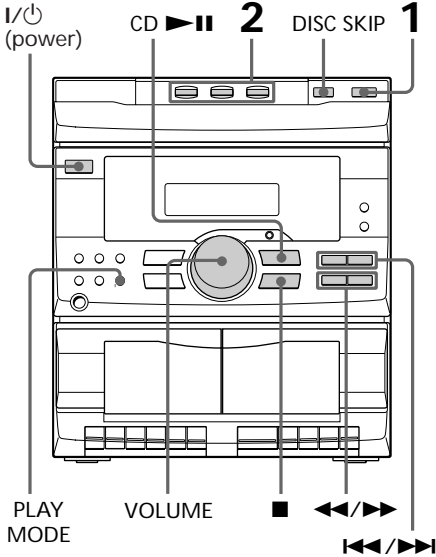

- 1 Press **▲** and place up to two CDs on the disc tray.  
If a disc is not placed properly, it will not be recognized.

With the label side up. When you play a single CD, place it on the inner circle of the tray.

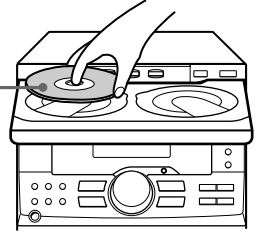

To insert a third disc, press DISC SKIP to rotate the disc tray.

- 2 Press one of the DISC 1 - 3 buttons. The disc tray closes and play starts. If you press CD ▶▶ (or ▶ on the remote) when the disc tray is closed, play starts from the CD loaded on the tray whose disc number is displayed.

Disc tray number

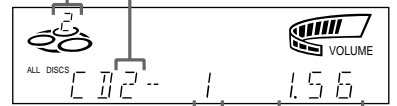

Track number

Playing time

continued

## Playing a CD (continued)

To	Do this
Stop play	Press ■.
Pause	Press CD ►   (or    on the remote). Press again to resume play.
Go to the next track or go back to the start of the current track	During play or pause, press ►► (to go forward) or ◀◀ (to go back).
Find a point in a track	Press and hold down ►► or ◀◀ during play and release it at the desired point.
Select a CD in stop mode	Press DISC SKIP.
Play only the CD you have selected	Press PLAY MODE repeatedly until "1 DISC" appears.
Play all CDs	Press PLAY MODE repeatedly until "ALL DISCS" appears.
Remove the CD	Press ▲ in stop mode.
Exchange other CDs while playing	Press ▲.
Adjust the volume	Turn VOLUME (or press VOL +/- on the remote).

## Tips

- Pressing CD ►|| when the power is off automatically turns the power on and starts CD playback if there is a CD in the tray (One Touch Play).
- You can switch from another source to the CD player and start playing a CD just by pressing CD ►|| or the DISC 1 – 3 buttons (Automatic Source Selection).
- If there is no CD in the player, "CD NO DISC" appears in the display.

# Recording a CD

You can use a TYPE I (normal) tape.

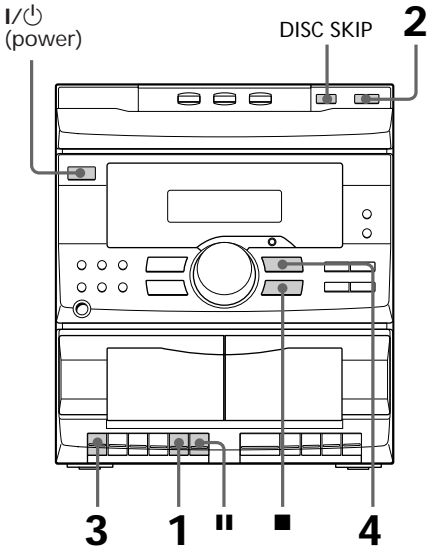

- 1 Press ■▲ and insert a blank tape into deck A.

With the side you want to record on facing forward

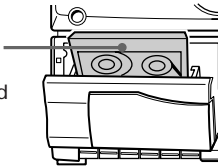

- 2 Press ▲ and place a CD. Then press again to close the disc tray. If the disc number you want to record is not displayed, press DISC SKIP repeatedly so that it appears.

With the label side up. When you play a single CD, place it on the inner circle of the tray.



- 3 Press ● on deck A. Recording starts.
- 4 Press CD ►II. The CD player starts playing.

## To stop recording

Press ■▲ on deck A and then ■.

## To pause recording

Press II on deck A.

## Notes

- While recording, do not rewind or fast-forward on the deck B. This causes an uneven sound to be recorded.
- You cannot listen to other sources while recording.

# Listening to the radio

## — Preset Tuning

Preset radio stations in the tuner's memory first (see "Step 3: Presetting radio stations").

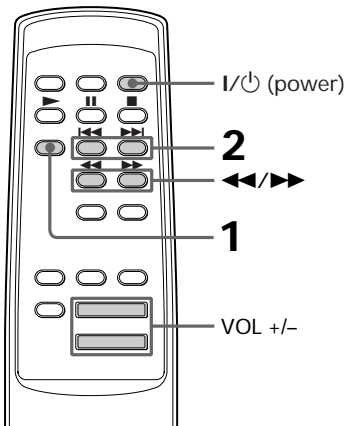
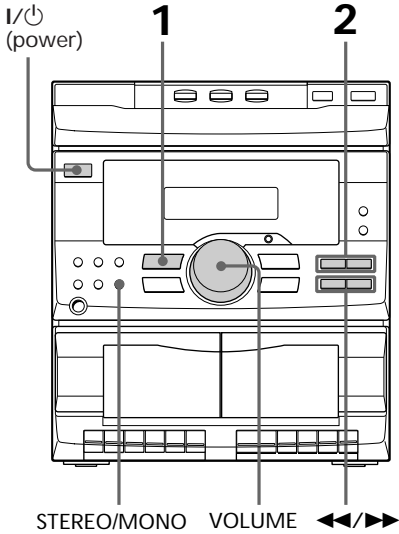

- 1 Press TUNER/BAND repeatedly until the band you want appears in the display.

Every time you press the button, the band changes as follows:

FM ↔ AM

- 2 Press ◀▶ or ▶▶ repeatedly to tune in the desired preset station. Press ◀▶ for lower preset numbers. Press ▶▶ for higher preset numbers.

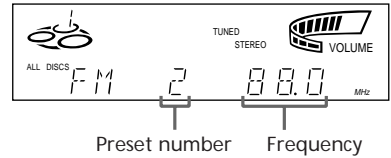

To	Do this
Turn off the radio	Press I/⏻ (power).
Adjust the volume	Turn VOLUME (or press VOL +/- on the remote).

## To listen to non-preset radio stations

### Automatic tuning

Press and hold ◀▶ or ▶▶ in step 2 until the frequency indication starts to change, then release it.

### Manual tuning

Press ◀▶ or ▶▶ repeatedly in step 2 to tune in the station.

### Tips

- Pressing TUNER/BAND when the power is off automatically turns the power on and tunes in the last received station (One Touch Play).
- You can switch from another source to the radio just by pressing TUNER/BAND (Automatic Source Selection).
- When an FM program is noisy, press STEREO/MONO so that "MONO" appears in the display. There will be no stereo effect, but the reception will improve. Press the button again to restore the stereo effect.
- To improve broadcast reception, reorient the supplied antennas.

# Recording from the radio

You can record the radio program on a tape by calling up a preset station. You can use a TYPE I (normal) tape.

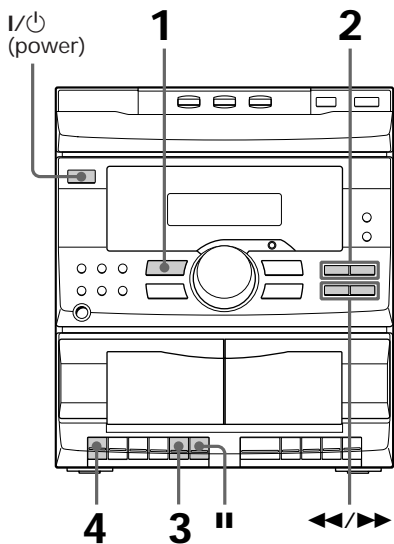

**1** Press TUNER/BAND to select the band you want.

**2** Press ◀◀ or ▶▶ repeatedly to tune in a preset station.  
Press ◀◀ for lower preset numbers.  
Press ▶▶ for higher preset numbers.

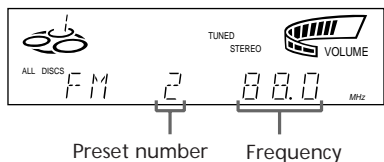

Preset number

Frequency

**3** Press ■▲ and insert a blank tape into deck A.

With the side you want to record on facing forward

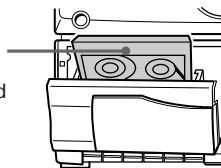

**4** Press ● on deck A.  
Recording starts.

## To stop recording

Press ■▲ on deck A.

## To pause recording

Press || on deck A.

## Tips

- To record non-preset stations, use ◀◀ and ▶▶ in step 2 to tune in the desired station.
- If noise is heard while recording from the radio, move the respective antenna to reduce the noise.

# Playing a tape

You can use a TYPE I (normal) tape.

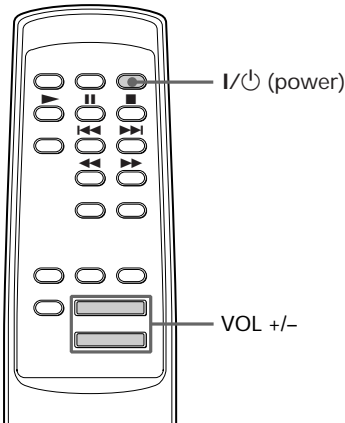
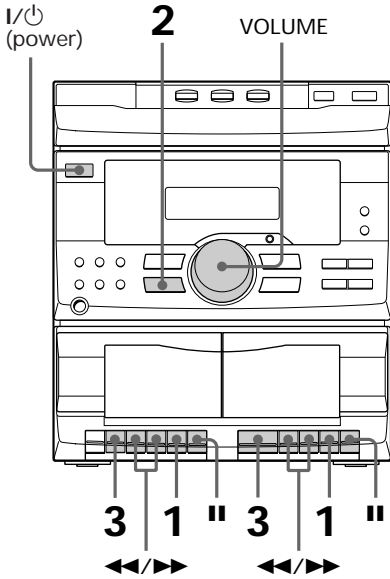

- 1 Press **■▲** and insert a recorded tape in deck A or B.

With the side you want to play facing forward

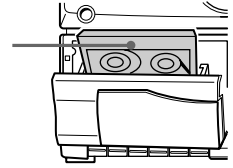

- 2 Press **TAPE**.  
"TAPE" appears in the display.
- 3 Press **▶** on deck A or B.  
The tape starts playing.

To	Do this
Stop play	Press <b>■▲</b> .
Pause	Press <b>  </b> . Press again to resume play.
Fast-forward	Press <b>▶▶</b> .
Rewind	Press <b>◀◀</b> .
Remove the cassette	Press <b>■▲</b> .
Adjust the volume	Turn <b>VOLUME</b> (or press <b>VOL +/-</b> on the remote).

## To play both decks in succession (relay play)

You can listen to one side of the tapes in deck B and deck A in succession. When the tape in deck B finishes playing, the tape in deck A starts playing.

- 1 Press **■▲** and insert recorded tapes in both decks.
- 2 Press **▶** on deck B.
- 3 Press **||** and **▶** on deck A.  
The tape on deck A is paused and automatically released when the playback on deck B ends.

### Tip

If you play both decks at the same time, you will hear the sound from deck B.

# Recording from a tape

You can use a TYPE I (normal) tape.

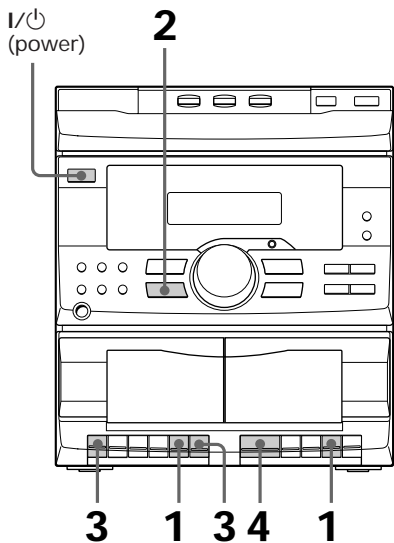

**3** Press **II** and then **●** on deck A.  
Deck A stands by for recording.

**4** Press **▶** on deck B.  
The tape starts dubbing.

## To stop recording

Press **■▲** on deck A and B.

## To pause recording

Press **II** on deck A.

**1** Press **■▲** and insert a recorded tape in deck B and a blank tape in deck A.

With the side you want to play/record on facing forward

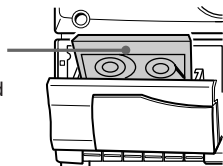

**2** Press **TAPE**.  
“TAPE” appears in the display.

## Using the CD display

You can check the remaining time of the current track.

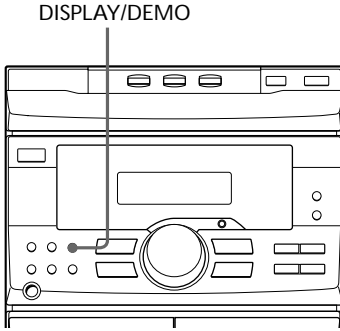

➔ Press DISPLAY/DEMO during playback.

Each time you press the button during normal playback, the display changes as follows:

- Playing time on the current track
- ↓
- Remaining time on the current track
- ↓
- Disc tray number and "PLAY"
- ↓
- Clock display (for about 10 seconds)
- ↓
- Effect name or "FLAT"

## Playing the CD tracks repeatedly

### -- Repeat Play

This function lets you repeat a single CD or all CDs in normal play, Shuffle Play and Program Play.

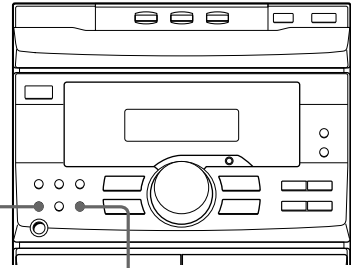

➔ Press REPEAT during playback until "REPEAT" appears in the display.

Repeat Play starts. Do the following procedure to change the repeat mode.

To repeat	Press
All the tracks on the current CD	PLAY MODE repeatedly until "1 DISC" appears in the display.
All the tracks on all CDs	PLAY MODE repeatedly until "ALL DISCS" appears in the display.
Only one track	REPEAT repeatedly until "REPEAT 1" appears in the display while playing the track you want to repeat.



## To cancel Repeat Play

Press REPEAT so that “REPEAT” or “REPEAT 1” disappears from the display.

---

# Playing the CD tracks in random order

## — Shuffle Play

You can play all the tracks on one CD or all the CDs in random order.

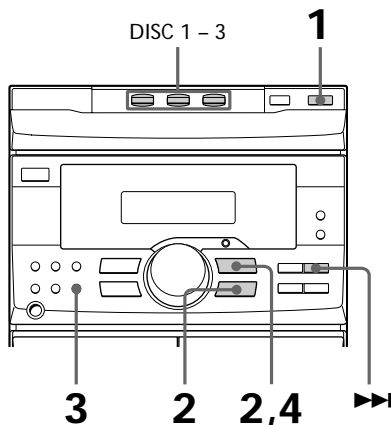

- 
- 1 Place CDs on the disc tray.

---

  - 2 Press CD ►|| and then ■.

---

  - 3 Press PLAY MODE repeatedly until “1 DISC SHUFFLE ” or “ALL DISCS SHUFFLE” appears in the display. “ALL DISCS” shuffles all the CDs in the player. “1 DISC” shuffles the CD whose disc tray number is displayed.

---

  - 4 Press CD ►||. “◀▶” appears and then all the tracks play in random order.
- 

continued

## Playing the CD tracks in random order (continued)

### To cancel Shuffle Play

Press PLAY MODE repeatedly until "SHUFFLE" or "PROGRAM" disappears from the display. The tracks continue playing in their original order.

### To select a desired CD

Press DISC 1 - 3.

### Tips

- You can start Shuffle Play during normal play by pressing PLAY MODE repeatedly to select "SHUFFLE".
- To skip a track, press ►►.

## Programming the CD tracks

### -- Program Play

You can make a program of up to 32 tracks from all the CDs in the order you want them to be played.

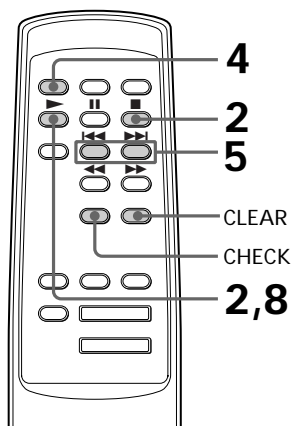
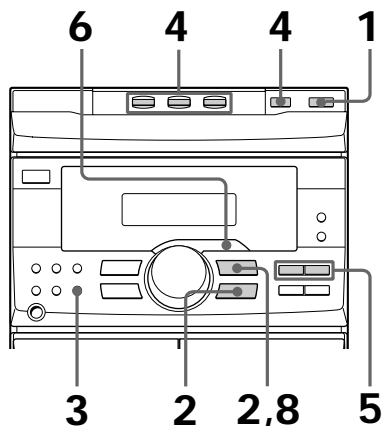

- 1 Place CDs on the disc tray.
- 2 Press CD ►|| (or ► on the remote) and then ■.
- 3 Press PLAY MODE repeatedly until "PROGRAM" appears in the display.
- 4 Press one of the DISC 1 - 3 buttons or DISC SKIP repeatedly to select a CD.
- 5 Press ◀◀ or ▶▶ repeatedly until the desired track appears in the display.

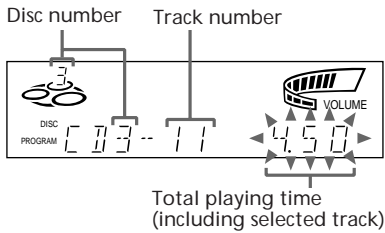

- 6 Press ENTER/NEXT.  
The track is programmed and the program step number appears.

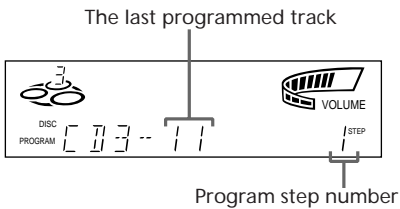

- 7 To program additional tracks, repeat steps 4 to 6.  
Skip step 4 to select tracks from the same disc.
- 8 Press CD ►|| (or ► on the remote).  
All the tracks play in the order you selected.

### To cancel Program Play

Press PLAY MODE repeatedly until "PROGRAM" or "SHUFFLE" disappears from the display.

continued

## Programming the CD tracks (continued)

To	Press
Check the program	CHECK on the remote repeatedly. After the last track, "CHECK END" appears.
Clear a track from the end	CLEAR on the remote in stop mode.
Clear a specific track	CHECK on the remote repeatedly until the number of the track to be erased appears, then press CLEAR.
Add a track to the program	1 Press one of the DISC 1 - 3 buttons or DISC SKIP to select a CD. 2 Select the track by pressing <b>⏮</b> or <b>⏭</b> . 3 Press ENTER/NEXT.
Clear the entire program	■ once in stop mode or twice while playing.

## Tips

- The program you made remains in the CD player even after it has been played back. Press CD **▶||** to play the same program again.
- If the total playing time does not appear while programming, this means:
  - you have programmed a track number which exceeds 20, or
  - the total playing time has exceeded 100 minutes.
- "FULL" appears when you try to program over 32 tracks.

## Recording CDs by specifying the track order

### — Program Edit

You can record tracks from all the CDs in the order you want. When programming, make sure the playing times for each side do not exceed the length of one side of the tape.

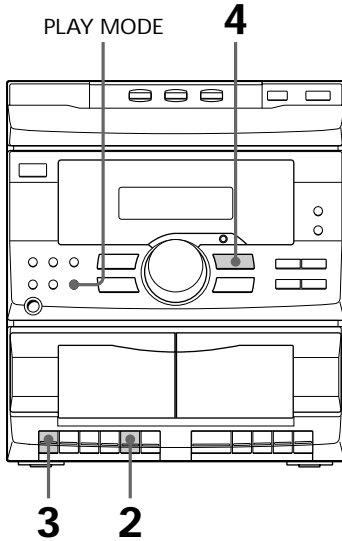

- 1 Follow steps 1 to 7 in “Programming the CD tracks” (see page 19).
- 2 Press **■▲** and insert a blank tape into deck A.
- 3 Press **●** on deck A. Recording starts.
- 4 Press CD **▶||**. The tracks play in the order you selected.

### To stop recording

Press **■▲** on deck A.

### To cancel Program Edit

Press PLAY MODE repeatedly until “PROGRAM” or “SHUFFLE” disappears from the display.

continued

## Recording CDs by specifying the track order (continued)

### Selecting tape length automatically

#### —Tape Select Edit

You can check the most suitable tape length for recording a CD. Note that you cannot use Tape Select Edit for discs containing over 20 tracks.

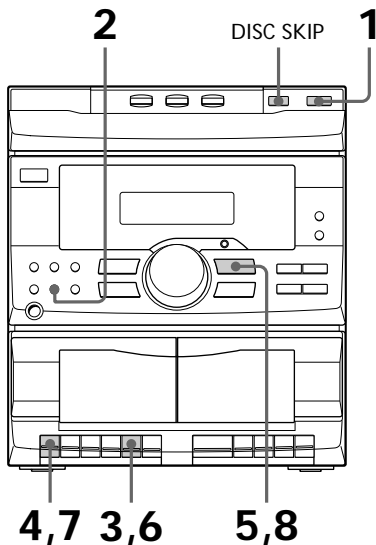

- 1 Place a CD on the disc tray.  
If the disc number you want to record is not displayed, press DISC SKIP repeatedly so that it appears.
- 2 Press EDIT.  
The required tape length for the currently selected CD appears, followed by the total playing time for sides A and B respectively.

- 3 Press **■▲** and insert a blank tape in deck A.
- 4 Press **●** on deck A.  
Recording starts.
- 5 Press CD **▶||**.  
The CD player starts playing the tracks to be recorded on side A.  
When the last track for side A finishes playing, the CD player changes to playing pause automatically.
- 6 Remove the tape from deck A, and insert it again with the side B facing forward. Then rewind the tape completely.
- 7 Press **●** on deck A.  
Recording starts for side B.
- 8 Press CD **▶||**.  
The CD player starts playing the tracks to be recorded on side B.

#### Note

You cannot use this function after programming. In order to use this function, you must first erase the program (see "Clear the entire program" in the table on page 20).

### Adjusting the sound

You can reinforce the bass and listen with headphones.

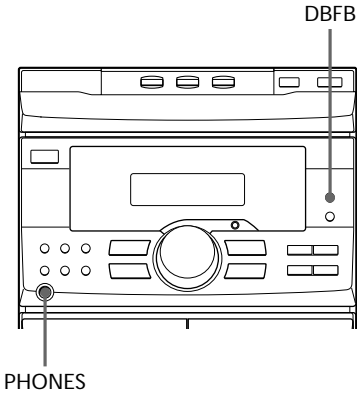

#### To reinforce bass (DBFB)

Press DBFB\*.

“DBFB ” appears in the display.

To cancel DBFB, press DBFB so that “DBFB ” disappears from the display.

\* DBFB = Dynamic Bass Feedback

#### To listen through the headphones

Connect the headphones to PHONES jack.  
No sound will come from the speakers.

### Selecting the audio emphasis

The audio emphasis menu lets you select the sound characteristic according to the sound you are listening to.

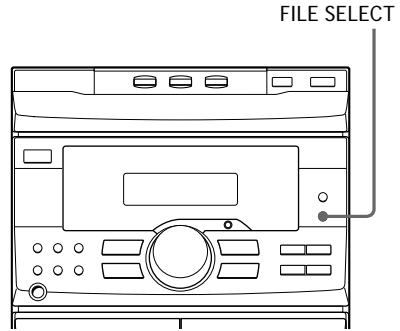

---

➔ Press FILE SELECT repeatedly until the effect you desire (ROCK, POP or DANCE) appears in the display.

---

#### To cancel the effect

Press FILE SELECT repeatedly until “FLAT” appears in the display.

## Falling asleep to music

### — Sleep Timer

You can let the system turn off at the preset time, so you can sleep to the CD. You can preset the time to be turned off by 10 minutes.

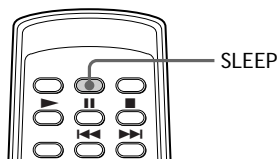

➔ Press SLEEP.

Every time you press the button, the minute display (the turn-off time) changes as follows:

AUTO → 90min → 80min → 70min  
→ ... → 10min → OFF → AUTO ...

### When you choose AUTO

The power turns off when the current CD finishes playback (for up to 100 minutes).

### To check the remaining time

Press SLEEP once.

### To change the time to turn off

Select the time you want by pressing SLEEP.

### To cancel the Sleep Timer function

Press SLEEP repeatedly until "OFF" appears.

## Waking up to music

### — Wake-up Timer

You can wake up to music at a preset time every day. Make sure you have set the clock (see "Step 2: Setting the time").

The 24-hour system model is used for illustration purpose.

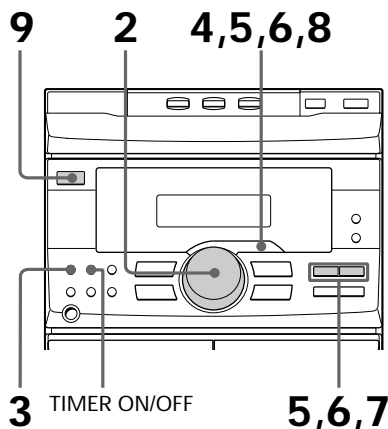

**1** Prepare the music source you want to play.

- CD: Place a CD. To start from a specific track, make a program (see "Programming the CD tracks").
- Radio: Tune in the preset station you want (see "Step 3: Presetting radio stations").

**2** Turn VOLUME to adjust the volume.



- 
- 3** Press CLOCK/TIMER SET.  
“SET DAILY” appears.
- 

- 4** Press ENTER/NEXT.  
“ON” appears and the hour digits flash in the display.



- 
- 5** Set the time to start playback.  
Press ◀◀ or ▶▶ repeatedly to set the hour, then press ENTER/NEXT.  
The minute indication starts flashing.

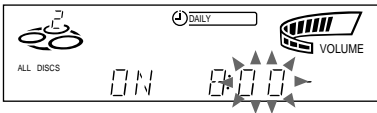

Press ◀◀ or ▶▶ repeatedly to set the minute, then press ENTER/NEXT.  
“OFF” appears and the hour indication flashes again.

---

- 6** Set the time to stop playback following the above procedure.
- 

- 7** Press ◀◀ or ▶▶ repeatedly until the music source you want appears.  
The indications change as follows:  
TUNER ↔ CD PLAY
- 

- 8** Press ENTER/NEXT.  
The start time, followed by the stop time and the music source, appears, then the original display appears.
- 

- 9** Turn off the power.
- 

### To check the setting

Press TIMER ON/OFF to turn on the DAILY indication in the display.

To change the setting, start over from step 1.

### To cancel the timer operation

Press TIMER ON/OFF to turn off the DAILY indication.

“TIMER OFF” appears in the display.

### Tips

- The power turns on 15 seconds before the preset time.
- You cannot set the time if the timer on and off times are the same.
- When you set the Sleep Timer, the Wake-up Timer will not turn on the system until the Sleep Timer turns it off.

## Precautions

### On operating voltage

Before operating the system, check that the operating voltage of your system is identical with the voltage of your local power supply.

### On safety

- The unit is not disconnected from the AC power source (mains) as long as it is connected to the wall outlet, even if the unit itself has been turned off.
- Unplug the system from the wall outlet (mains) if it is not to be used for an extended period of time. To disconnect the cord (mains lead), pull it out by the plug. Never pull the cord itself.
- Should any solid object or liquid fall into the component, unplug the stereo system and have the component checked by qualified personnel before operating it any further.
- The AC power cord must be changed only at the qualified service shop.

### On placement

- Place the stereo system in a location with adequate ventilation to prevent heat build-up in the stereo system.
- Do not place the unit in an inclined position.
- Do not place the unit in locations where it is;
  - Extremely hot or cold
  - Dusty or dirty
  - Very humid
  - Vibrating
  - Subject to direct sunlight

### On operation

- If the stereo system is brought directly from a cold to a warm location, or is placed in a very damp room, moisture may condense on the lens inside the CD player. Should this occur, the system will not operate properly. Remove the CD and leave the system turned on for about an hour until the moisture evaporates.
- When you move the system, take out any discs.

If you have any questions or problems concerning your stereo system, please consult your nearest Sony dealer.

## Notes on CDs

- Before playing, clean the CD with a cleaning cloth. Wipe the CD from the center out.
- Do not use solvents such as benzene, thinner, commercially available cleaners or anti-static spray intended for vinyl LPs.
- Do not expose the CD to direct sunlight or heat sources such as hot air ducts, nor leave it in a car parked in direct sunlight.

## Cleaning the cabinet

Use a soft cloth slightly moistened with mild detergent solution.

## To save a tape permanently

To prevent a tape from being accidentally recorded over, break off the cassette tab from side A or B as illustrated.

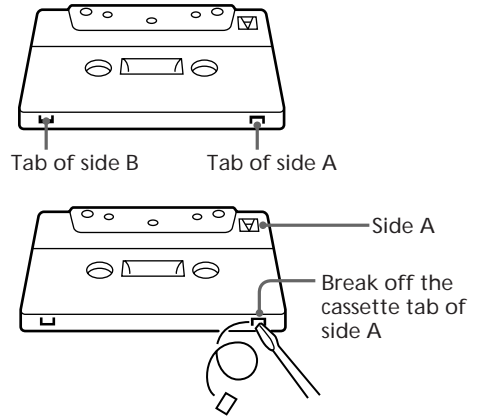

If you later want to reuse the tape for recording, cover the broken tab with adhesive tape.

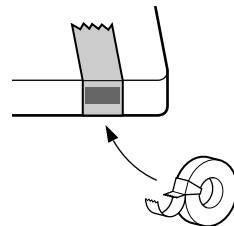

## Before placing a cassette in the tape deck

Take up any slack in the tape. Otherwise the tape may get entangled in the parts of the tape deck and become damaged.

## When using a tape longer than 90 minutes

The tape is very elastic. Do not change the tape operations such as play, stop, and fast-winding etc. frequently. The tape may get entangled in the tape deck.

## Cleaning the tape heads

Clean the tape heads after every 10 hours of use. When the tape heads become dirty

- the sound is distorted
- there is a decrease in sound level
- the sound drops out
- the tape does not erase completely
- the tape does not record

Make sure to clean the tape heads before you start an important recording or after playing an old tape. Use separately sold dry-type or wet-type cleaning cassette. For details, refer to the instructions of the cleaning cassette.

## Demagnetizing the tape heads

Demagnetize the tape heads and the metal parts that have contact with the tape every 20 to 30 hours of use with a separately sold demagnetizing cassette. For details, refer to the instructions of the demagnetizing cassette.

---

# Troubleshooting

If you run into any problem using this stereo system, use the following check list.

First, check that the power cord is connected firmly and the speakers are connected correctly and firmly.

Should any problem persist, consult your nearest Sony dealer.

## General

---

The display starts flashing as soon as you plug in the power cord even though you haven't turned on the power (demonstration mode).

- Press DISPLAY/DEMO when the power is turned off.

The demonstration mode appears automatically the first time you plug in the power cord. If there is a power outage lasting longer than half a day, redo the following:

- Clock setting (see "Step 2: Setting the time")
- Preset stations (see "Step 3: Presetting radio stations")
- Timer settings (see "Waking up to music")

---

There is no sound.

- Turn VOLUME clockwise.
- The headphones are connected.
- Insert only the stripped portion of the speaker cord into the SPEAKER jack. Inserting the vinyl portion of the speaker cord will obstruct the speaker connections.

continued

## Troubleshooting (continued)

---

There is severe hum or noise.

- A TV or VCR is placed too close to the stereo system. Move the stereo system away from the TV or VCR.
- 

“0:00” (or “12:00AM”) flashes in the display.

- A power failure occurred. Set the clock and timer settings again.
- 

The timer does not function.

- Set the clock correctly.
- 

“DAILY” does not appear when you press the TIMER ON/OFF button.

- Set the timer correctly.
  - Set the clock.
- 

The remote does not function.

- There is an obstacle between the remote and the system.
  - The remote is not pointing in the direction of the system’s sensor.
  - The batteries have run down. Replace the batteries.
- 

There is acoustic feedback.

- Decrease the volume level.
- 

The color irregularity on a TV screen persists.

- Place the speakers farther away from the TV set.
- 

## Speakers

---

Sound comes from one channel or unbalanced left and right volume.

- Check the speaker connection and speaker placement.
- 

## CD Player

---

The CD tray does not close.

- The CD is not placed properly.
- 

The CD will not play.

- The CD is not lying flat in the disc tray.
  - The CD is dirty.
  - The CD is inserted label side down.
  - Moisture condensation has built up. Remove the CD and leave the system turned on for about an hour until the moisture evaporates.
- 

Play does not start from the first track.

- The player is in Program or Shuffle Play mode. Press PLAY MODE repeatedly until “PROGRAM” or “SHUFFLE” disappears.
- 

“OVER” is displayed.

- You have reached the end of the CD. Press and hold ◀◀ to return.
-

## Tape Deck

---

The tape does not record.

- No tape in the cassette holder.
- The tab has been removed from the cassette (see “To save a tape permanently” on page 26).
- The tape has reeled to the end.

The tape does not record nor play or there is a decrease in sound level.

- The heads are dirty. Clean them (see “Cleaning the tape heads” on page 27).
- The record/playback heads are magnetized. Demagnetize them (see “Demagnetizing the tape heads” on page 27).

The tape does not erase completely.

- The record/playback heads are magnetized. Demagnetize them (see “Demagnetizing the tape heads” on page 27).

There is excessive wow or flutter, or the sound drops out.

- The capstans or pinch rollers are dirty. Clean them (see “Cleaning the tape heads” on page 27).

Noise increases or the high frequencies are erased.

- The record/playback heads are magnetized. Demagnetize them (see “Demagnetizing the tape heads” on page 27).
- 

## Tuner

---

Severe hum or noise (“TUNED” or “STEREO” flashes in the display).

- Adjust the antenna.
- The signal strength is too weak. Connect the external antenna.

A stereo FM program cannot be received in stereo.

- Press STEREO/MONO so that “STEREO” appears.
- 

**If other troubles not described above occur, reset the system as follows:**

- 1 Unplug the power cord.
- 2 Plug the power cord back in.

# Specifications

## AUDIO POWER SPECIFICATIONS: (U.S.A. model only)

### POWER OUTPUT AND TOTAL HARMONIC DISTORTION:

with 6 ohm loads both channels driven, from 70-20,000 Hz; rated 25 watts per channel minimum RMS power, with no more than 0.9% total harmonic distortion from 250 milliwatts to rated output.

## Amplifier section

### North American model

Continuous RMS power output  
35 watts + 35 watts  
(6 ohms at 1 kHz,  
10% THD)

### European model

DIN power output (Rated)  
30 watts + 30 watts  
(6 ohms at 1 kHz, DIN)  
Continuous RMS power output (Reference)  
35 watts + 35 watts  
(6 ohms at 1 kHz,  
10% THD)  
Music power output (Reference)  
60 watts + 60 watts  
(6 ohms at 1 kHz,  
10% THD)

### Other models

The following measured at AC 110, 220 V 60 Hz;  
DIN power output (Rated)  
25 watts + 25 watts  
(6 ohms at 1 kHz, DIN)  
Continuous RMS power output (Reference)  
30 watts + 30 watts  
(6 ohms at 1 kHz,  
10% THD)

The following measured at AC 120, 240 V 60 Hz;  
DIN power output (Rated)  
30 watts + 30 watts  
(6 ohms at 1 kHz, DIN)  
Continuous RMS power output (Reference)  
35 watts + 35 watts  
(6 ohms at 1 kHz,  
10% THD)  
Peak music power output (Reference)  
400 watts

### Outputs

PHONES (stereo phone jack):  
accepts headphones of  
8 ohms or more

SPEAKER:  
accepts impedance of 6 to  
16 ohms

## CD player section

System Compact disc and digital audio system  
Laser Semiconductor laser ( $\lambda = 780 \text{ nm}$ )  
Emission duration: continuous  
Laser output Max.  $44.6 \mu\text{W}^*$   
\* This output is the value measured at a distance of 200 mm from the objective lens surface on the Optical Pick-up Block with 7 mm aperture.  
Frequency response 20 Hz - 20 kHz ( $\pm 0.5 \text{ dB}$ )  
Wavelength 780 - 790 nm

## Tape deck section

Recording system 4-track 2-channel stereo  
Frequency response 60 - 13,000 Hz ( $\pm 3 \text{ dB}$ ), using Sony TYPE I cassette  
Wow and flutter  $\pm 0.15\%$  W.Peak (IEC)  
 $0.1\%$  W.RMS (NAB)  
 $\pm 0.2\%$  W.Peak (DIN)

## Tuner section

FM stereo, FM/AM superheterodyne tuner

### FM tuner section

Tuning range 87.5 – 108.0 MHz  
Antenna FM lead antenna  
Antenna terminals 75 ohm unbalanced  
Intermediate frequency 10.7 MHz

### AM tuner section

Tuning range  
European, Australian and South African models: 531 – 1,602 kHz  
Other models: 530 – 1,710 kHz  
Antenna AM loop antenna  
Antenna terminals External antenna terminal  
Intermediate frequency 450 kHz

## Speaker

### European model

Speaker system 2-way, bass-reflex type  
Speaker units  
Woofer: 17 cm, cone type  
Tweeter: 5 cm, cone type  
Nominal impedance 6 ohms  
Dimensions (w/h/d) Approx. 220 x 320 x 238 mm  
(8<sup>3</sup>/<sub>4</sub> x 12<sup>5</sup>/<sub>8</sub> x 9<sup>3</sup>/<sub>8</sub> in)  
Mass Approx. 3.4 kg (7 lb 8 oz.)  
net per speaker

### Other models

Speaker system 2-way, bass-reflex type  
Speaker units  
Woofer: 13 cm, cone type  
Tweeter: 2 cm, PIEZO type  
Nominal impedance 6 ohms  
Dimensions (w/h/d) Approx. 220 x 320 x 216 mm  
(8<sup>3</sup>/<sub>4</sub> x 12<sup>5</sup>/<sub>8</sub> x 8<sup>3</sup>/<sub>8</sub> in)  
Mass Approx. 2.8 kg (6 lb 3 oz.)  
net per speaker

## General

### Power requirements

European model: 230 V AC, 50/60 Hz

Mexican model: 120 V AC, 50/60 Hz

Australian and South African models:

220 – 240 V AC, 50/60 Hz

Other models: 120 V AC, 60 Hz

### Power consumption

80 watts

Dimensions (w/h/d) incl. projecting parts and controls

Approx. 280 x 320 x 371 mm

(11<sup>1</sup>/<sub>8</sub> x 12<sup>5</sup>/<sub>8</sub> x 14<sup>5</sup>/<sub>8</sub> in)

### Mass

Approx. 7.2 kg

(15 lb 14 oz.)

### Supplied accessories:

AM loop antenna (1)

Remote RM-SG5 (1)

FM lead antenna (1)

Design and specifications are subject to change without notice.

---

# Index

## A

Adjusting  
  the sound 23  
  the volume 10, 12, 14  
Antennas 5, 8  
Automatic Source Selection  
  10, 12

## B

Batteries 5

## C

CD player 9, 11, 16  
Clock setting 6  
Connecting. *See* Hooking up

## D

Display 6, 7, 9, 16  
Dubbing 15

## E, F, G

Edit 21, 22

## H, I, J, K, L, M

Hooking up  
  the antennas 5, 8  
  the power 5  
  the system 4

## N

Normal Play 9

## O

One Touch Play 10, 12

## P, Q

Playing  
  a CD 9  
  a preset radio station 12  
  a tape 14  
  tracks in random order  
  (Shuffle Play) 17  
  tracks in the desired  
  order (Program Play) 18  
  tracks repeatedly  
  (Repeat Play) 16  
Precautions 26  
Presetting radio stations 7  
Preset tuning 12  
Program Edit 21  
Program Play 18  
Protecting recordings 26

## R

Radio stations  
  presetting 7  
  tuning in 12  
Recording  
  a CD 11  
  a radio program 13  
  a tape 15  
  CDs by specifying the  
  track order 21  
  selecting tape length  
  automatically 22  
Repeat Play 16  
Resetting the system 29

## S

Saving recordings 26  
Selecting the audio emphasis  
  23  
Setting the time 6  
Shuffle Play 17  
Sleep Timer 24  
Sound adjustment 23  
Speakers 4

## T, U, V

Tape Select Edit 22  
Timer  
  falling asleep to music  
  24  
  waking up to music 24  
Troubleshooting 27  
Tuner 12, 13

## W, X, Y, Z

Wake-up timer 24